

# 68159

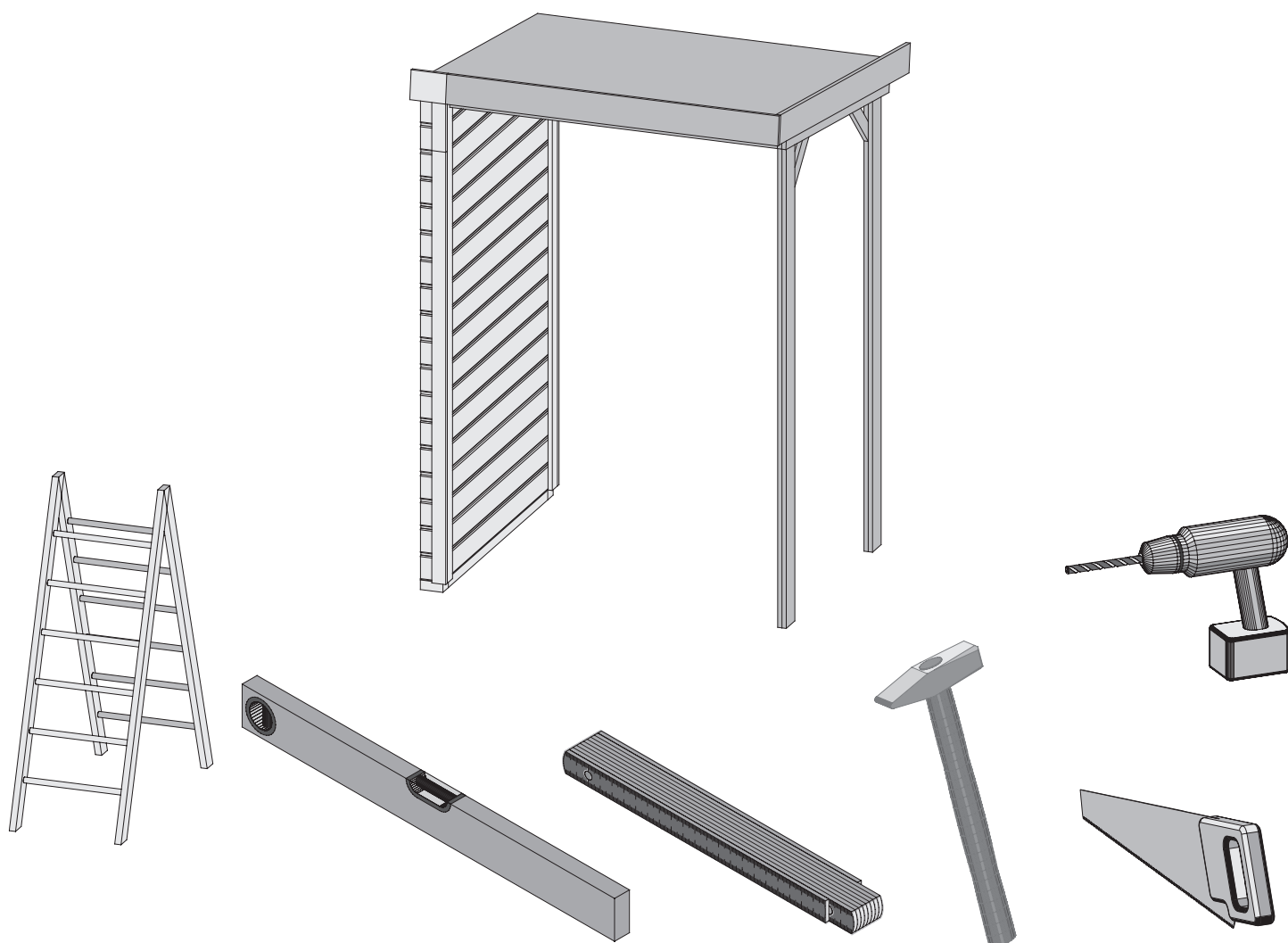

 **Aufbauanleitung**

 **notice de montage**

 **Building Instructions**

 **montagehandleiding**

 **Instrucciones de construcción**

 **Istruzioni per il montaggio**

 **Montážní návod**

 **Service-Hotline: +49 421 38693 33**



Vergleichen Sie zuerst die Materialliste mit Ihrem Paketinhalt! Bitte haben Sie Verständnis, dass Beanstandungen nur im nicht aufgebauten Zustand bearbeitet werden können!



Commencez par comparer la liste du matériel avec le contenu de votre paquet! Sachez que nous traitons uniquement les réclamations concernant le matériel à l'état non monté!



First compare the list of materials with your package contents! Please understand that complaints can be processed in the non-built status only!



Vergelijk eerst de lijst van materialen met de inhoud van uw pakket! Reclamaties kunnen alleen in behandeling worden genomen zolang de onderdelen nog niet zijn gemonteerd!



En primer lugar, compare la lista de material con el contenido del paquete. Rogamos entienda que las reclamaciones sólo pueden ser tramitadas antes de montar el objeto!



Confrontate questa distinta materiali prima con il contenuto del pacchetto! Vi preghiamo di comprendere che eventuali reclami possono essere accolti solo prima del montaggio!



68159

3 x B1	1800 x 45 x 18mm	ID 19546
1 x B2	1390 x 120 x 18mm	ID 67306

150 x		ID 3948
-------	--	---------

100 x	4 x 25mm	ID 5841
100 x	4 x 30mm	ID 3686
100 x	4 x 50mm	ID 3688
20 x	4 x 70mm	ID 3689

6 x		ID 21292
-----	--	----------

1 x E1	1150 x 95 x 36mm	ID 67304
3 x E2	1370 x 95 x 36mm	ID 67303

2 x K1	400 x 58 x 18mm	ID 67300

2 x G1	2095 x 95 x 36mm	ID 67291

1 x D1	1400 x 460 x 16mm	ID 67305
1 x D2	1400 x 930 x 16mm	ID 24219

1 x	5m <sup>2</sup>	ID 5382

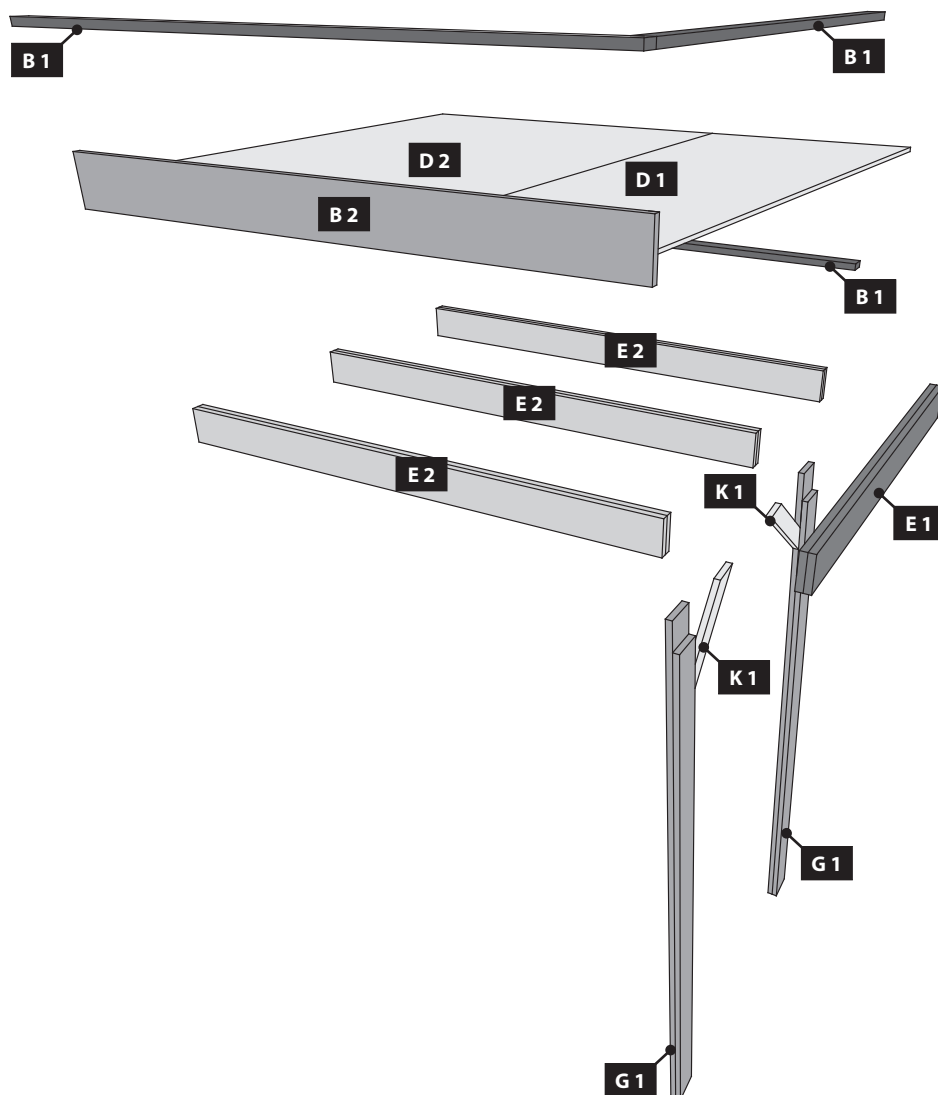

01 1x

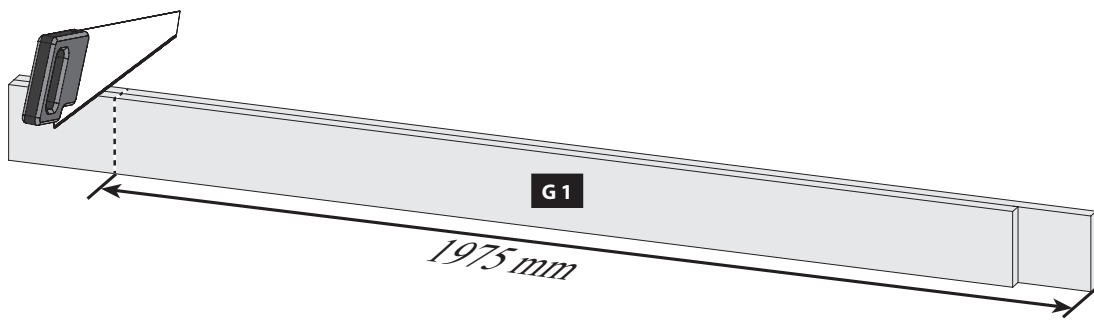

02

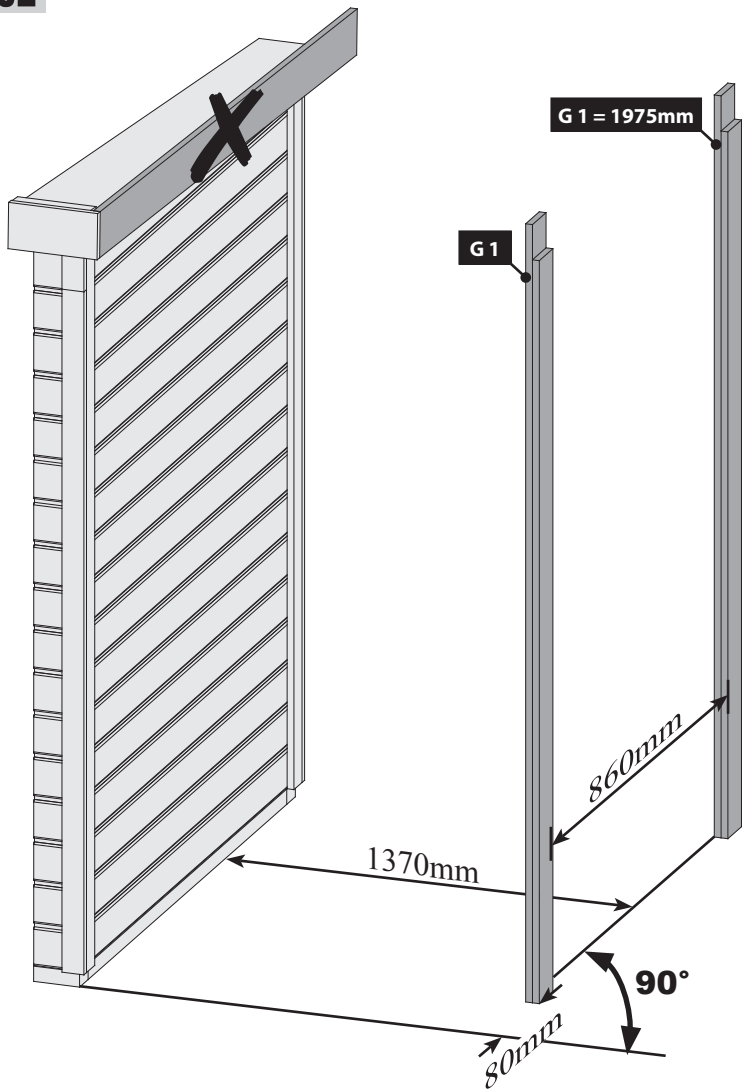

03

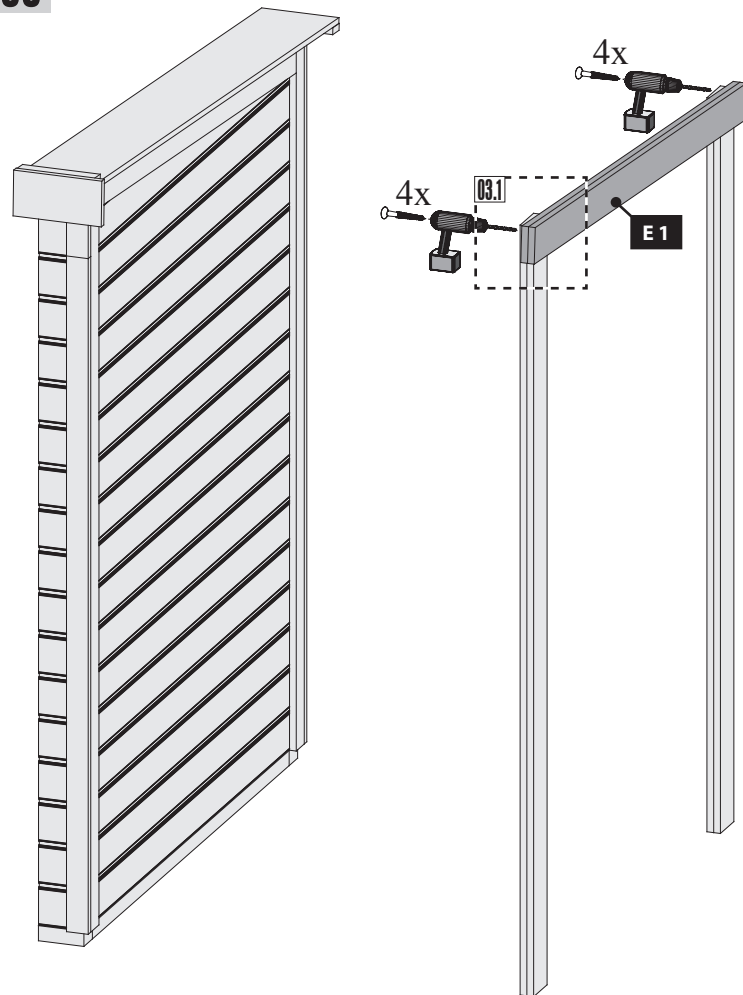

03.1

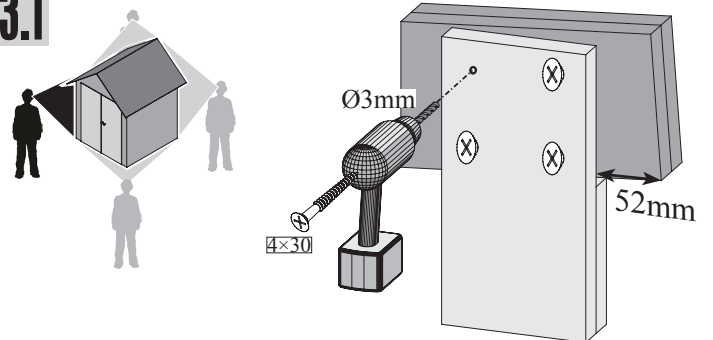

# 04 !!! A=B !!!

Bündig!  
Affleurement!  
Gelijk!  
Aras!  
Flush!  
Combacia!  
Flush!

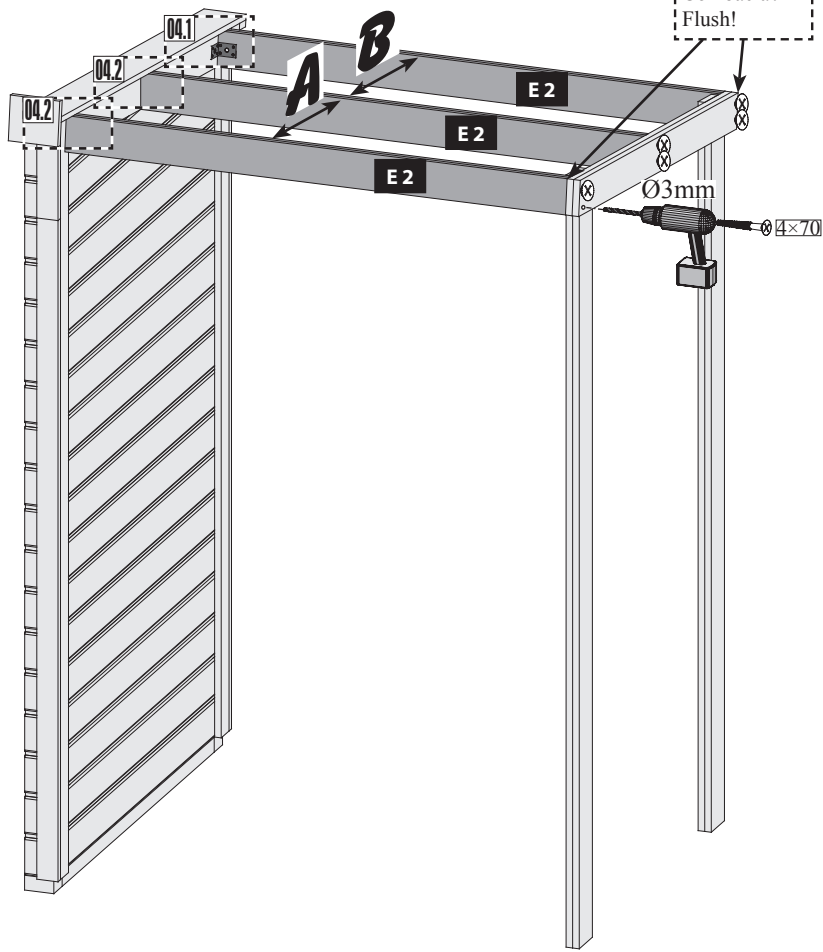

## 04.1

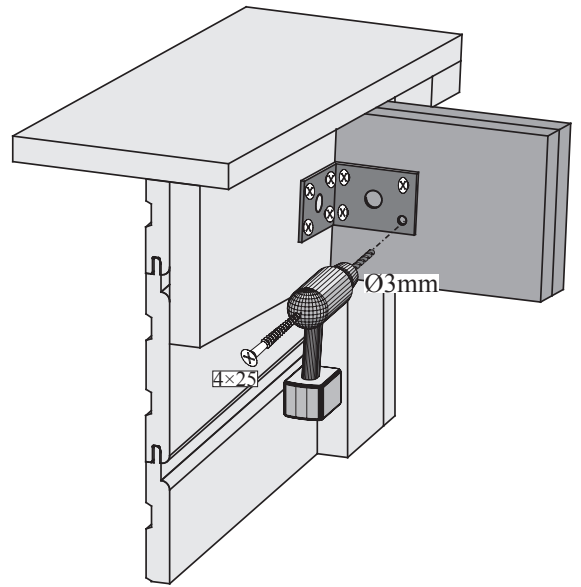

## 04.2

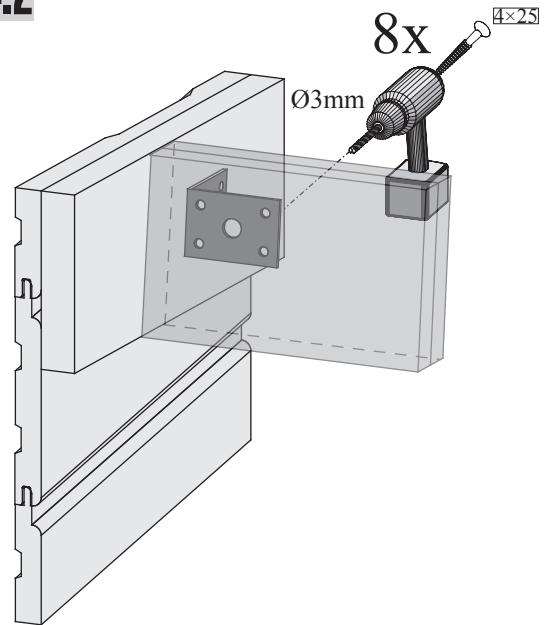

## 05

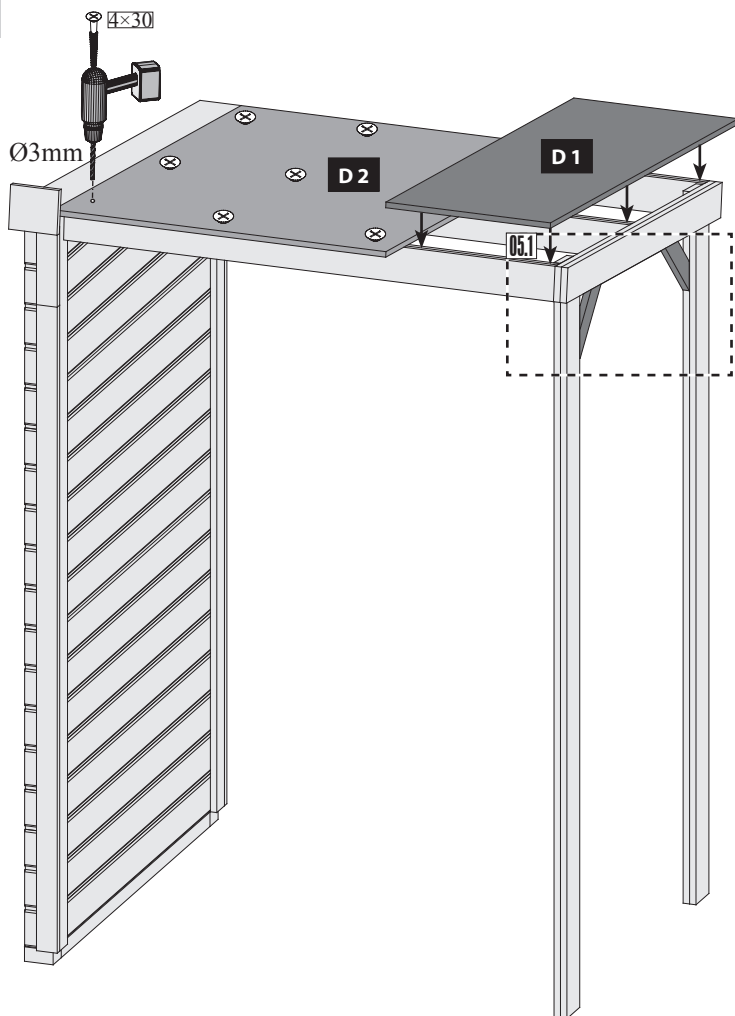

## 05.1

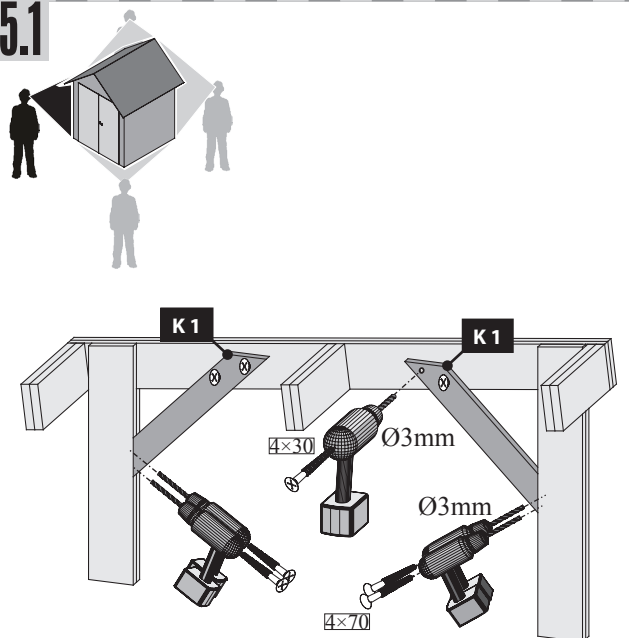

06

Bündig!  
Affleurement!  
Gelijk!  
Aras!  
Flush!  
Combacia!  
Flush!

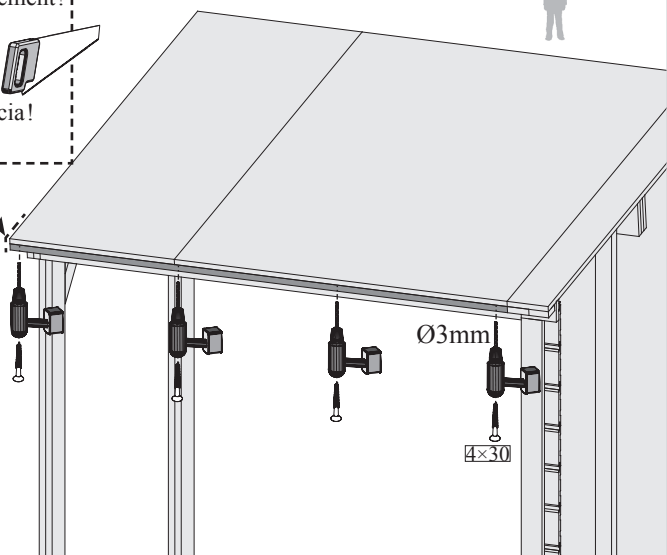
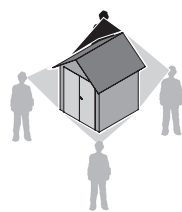



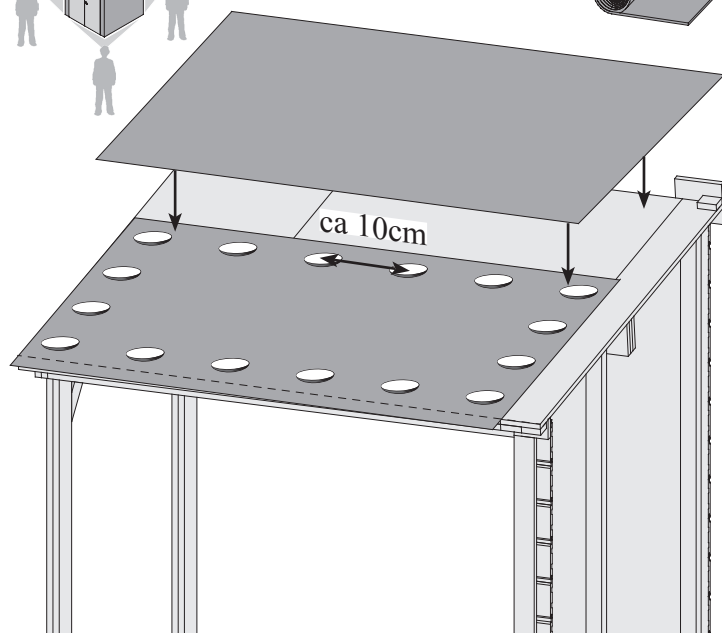
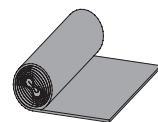
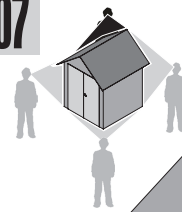

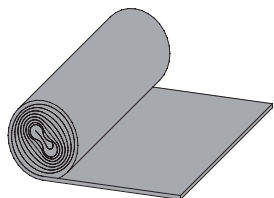

07



08



-  Die Eindeckung muss spätestens nach 2 Monaten durch ein geeignetes Produkt ergänzt werden
-  De vervanging mag niet later zijn dan twee maanden aangevuld met een geschikt product
-  The replacement must be no later than two months supplemented by a suitable product
-  Le remplacement ne doit pas être plus tard deux mois complétés par un produit adapté
-  El reemplazo debe ser no más tarde de dos meses complementan con un producto adecuado
-  La sostituzione deve essere entro e non oltre due mesi completate da un prodotto adatto
-  Pokrytí střechy musí být nejpozději po 2 měsících nahrazeno vhodným produktem.

Für die dauerhafte Eindeckung empfehlen wir die selbstklebende Bitumendachbahn (Artikelnummer 65757) aus unserem Sortiment. Die erforderliche Menge für das Haus und Schleppdach zusammen sind 2 Rollen.

09

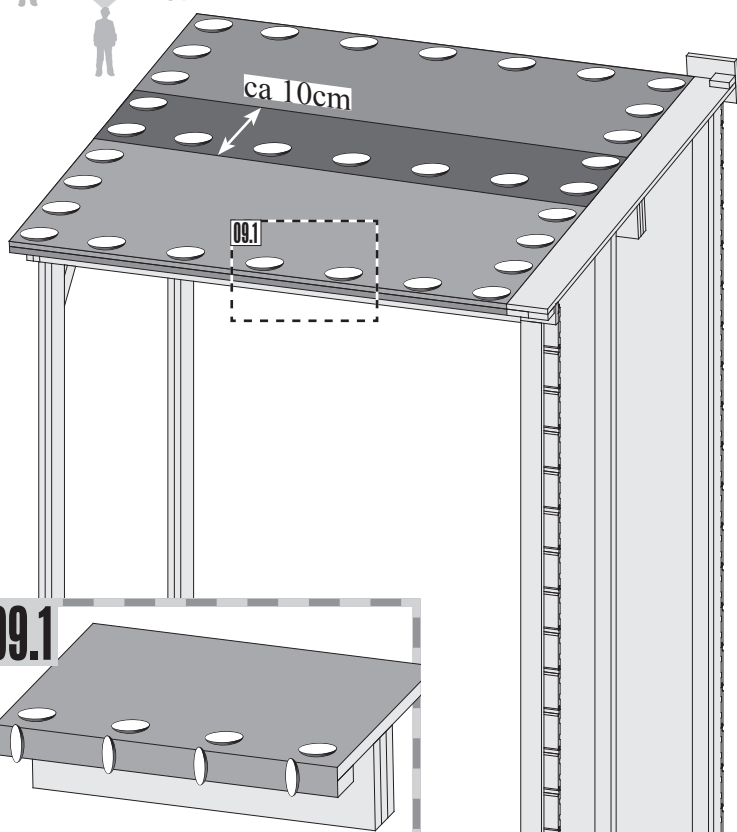
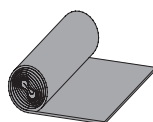
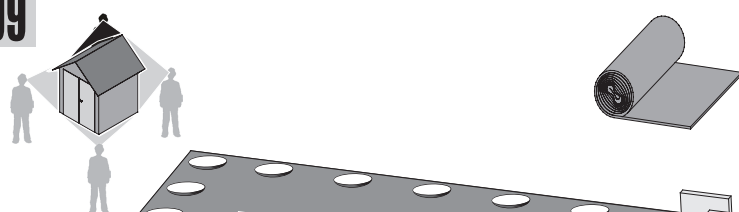

09.1

10

Bündig!  
Affleurement!  
Gelijk!  
Aras!  
Flush!  
Combacia!  
Flush!

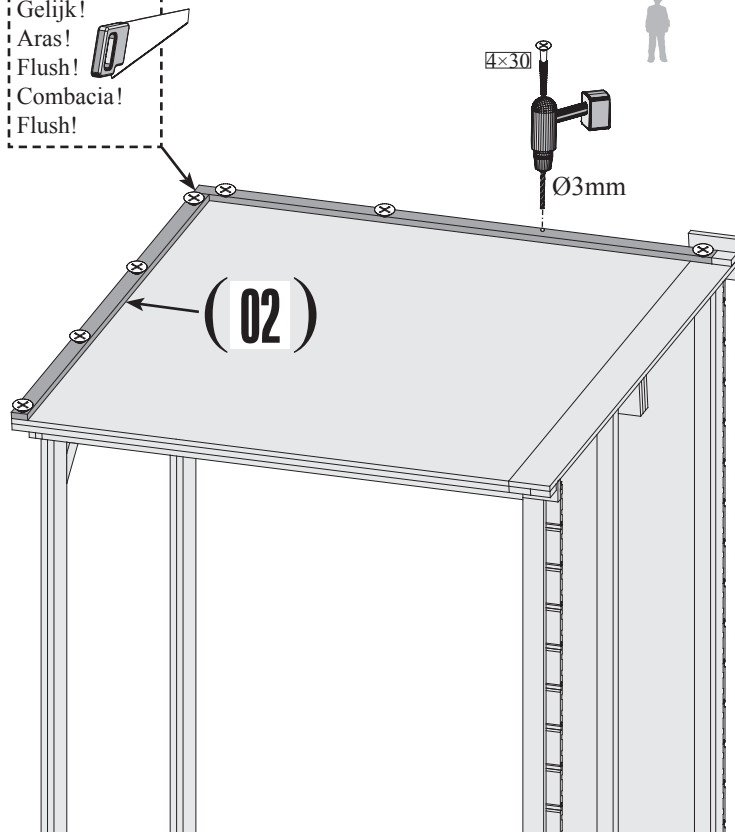
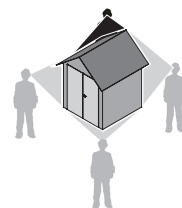

11

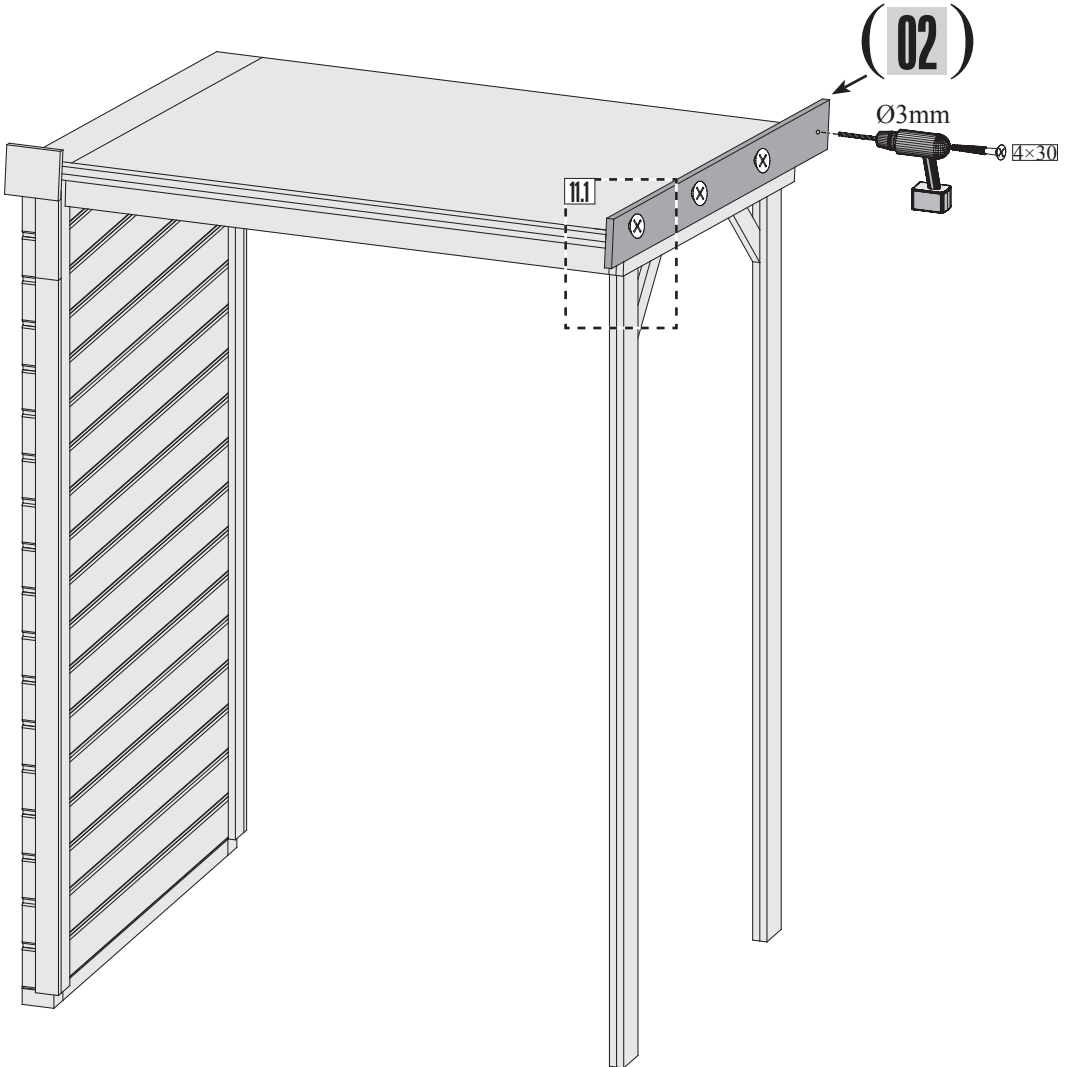

11.1

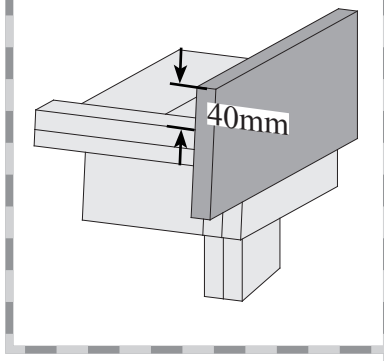

12

