

# 68330 68332

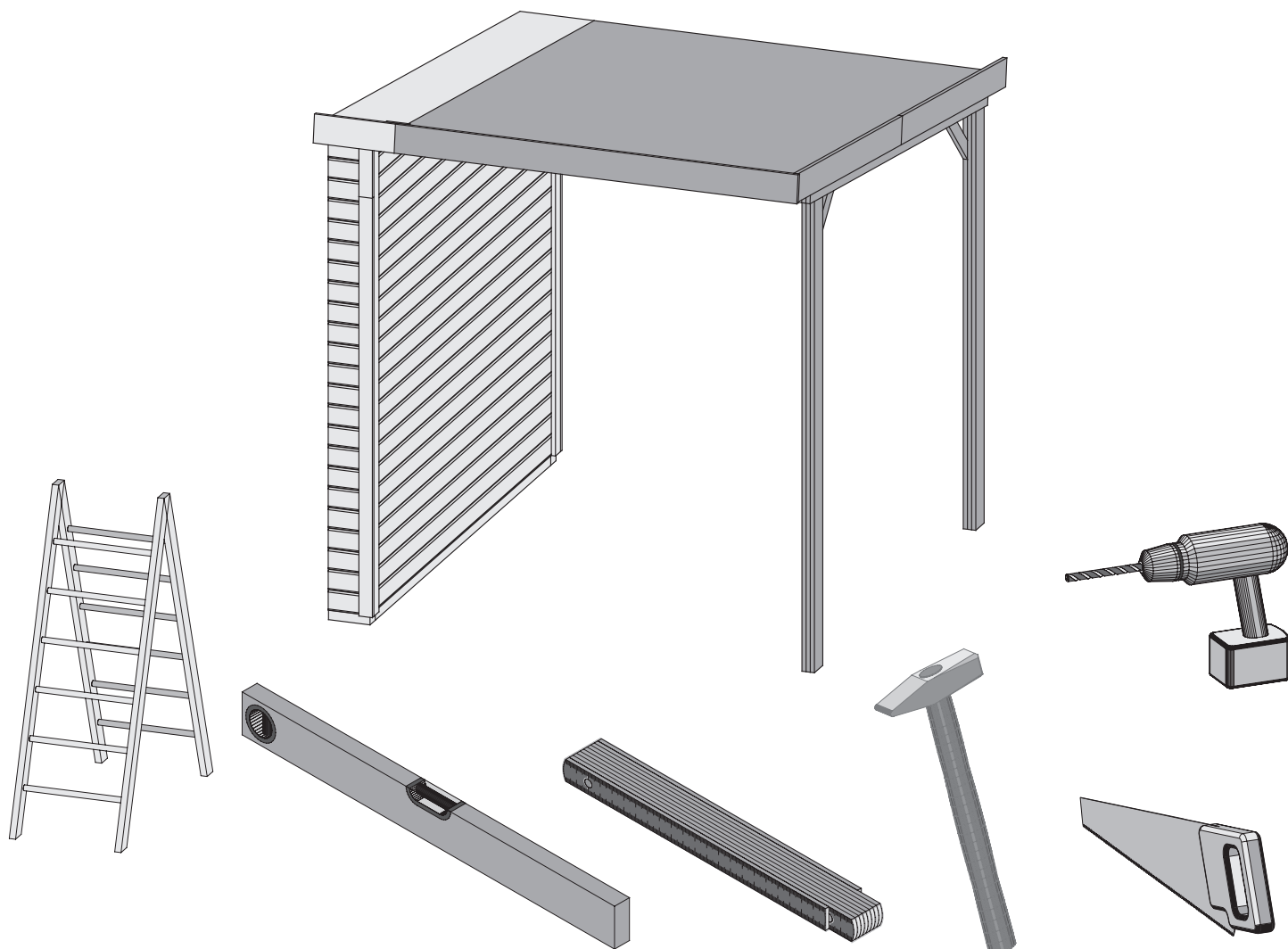

 **Aufbauanleitung**

 **notice de montage**

 **Building Instructions**

 **montagehandleiding**

 **Instrucciones de construcción**

 **Istruzioni per il montaggio**

 **Montážní návod**

 **Service-Hotline: +49 421 38693 33**



Vergleichen Sie zuerst die Materialliste mit Ihrem Paketinhalt! Bitte haben Sie Verständnis, dass Beanstandungen nur im nicht aufgebauten Zustand bearbeitet werden können!



Commencez par comparer la liste du matériel avec le contenu de votre paquet! Sachez que nous traitons uniquement les réclamations concernant le matériel à l'état non monté!



First compare the list of materials with your package contents! Please understand that complaints can be processed in the non-built status only!



Vergelijk eerst de lijst van materialen met de inhoud van uw pakket! Reclamaties kunnen alleen in behandeling worden genomen zolang de onderdelen nog niet zijn gemonteerd!



En primer lugar, compare la lista de material con el contenido del paquete. Rogamos entienda que las reclamaciones sólo pueden ser tramitadas antes de montar el objeto!



Confrontate questa distinta materiali prima con il contenuto del pacchetto! Vi preghiamo di comprendere che eventuali reclami possono essere accolti solo prima del montaggio!



**68330 68332**

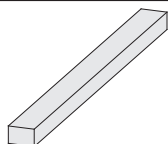

2 x B2	100 x 36 x 18mm	ID 59421
2 x B7	1800 x 45 x 18mm	ID 19546
1 x B21	1740 x 120 x 18mm	ID 27715

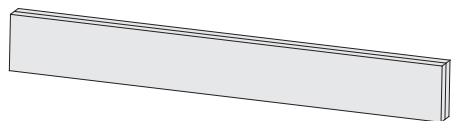

5 x E1	1826 x 95 x 36mm	ID 68388
1 x E2	2040 x 95 x 36mm	ID 67312

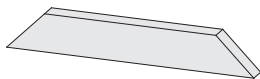

2 x K1	400 x 58 x 18mm	ID 67300
--------	-----------------	----------

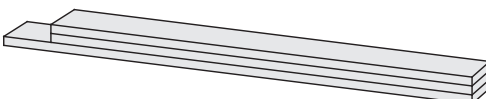

2 x P2	2110 x 95 x 54mm	ID 68375
--------	------------------	----------

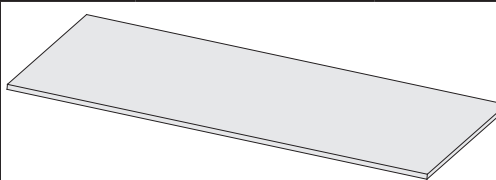

2 x D1	610 x 870 x 16mm	ID 58037
2 x D2	1740 x 870 x 16mm	ID 45414

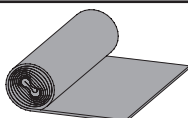

1 x	7,5m <sup>2</sup>	ID 3710
-----	-------------------	---------



100 x	4 x 25mm	ID 5841
100 x	4 x 30mm	ID 3686
100 x	4 x 50mm	ID 3688
20 x	4 x 70mm	ID 3689

200 x



ID 3948

10 x

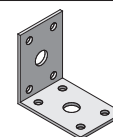

ID 21292



**Hinweis**

Die Pfosten dieses Produkts sollten fest mit dem Untergrund verbunden werden. Dazu empfehlen wir H-Pfostenanker. Diese sollten erst nach dem Aufbau dieses Produkts endgültig mit Beton versehen werden. **Die H-Pfostenanker und das zugehörige Befestigungsmaterial sind nicht im Lieferumfang dieses Produkts enthalten.**

01 1x

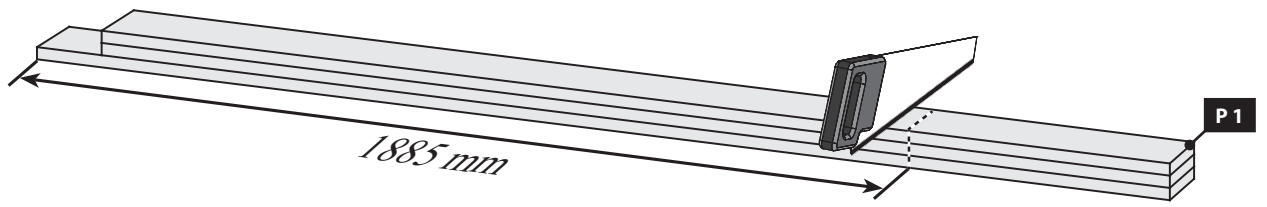

02

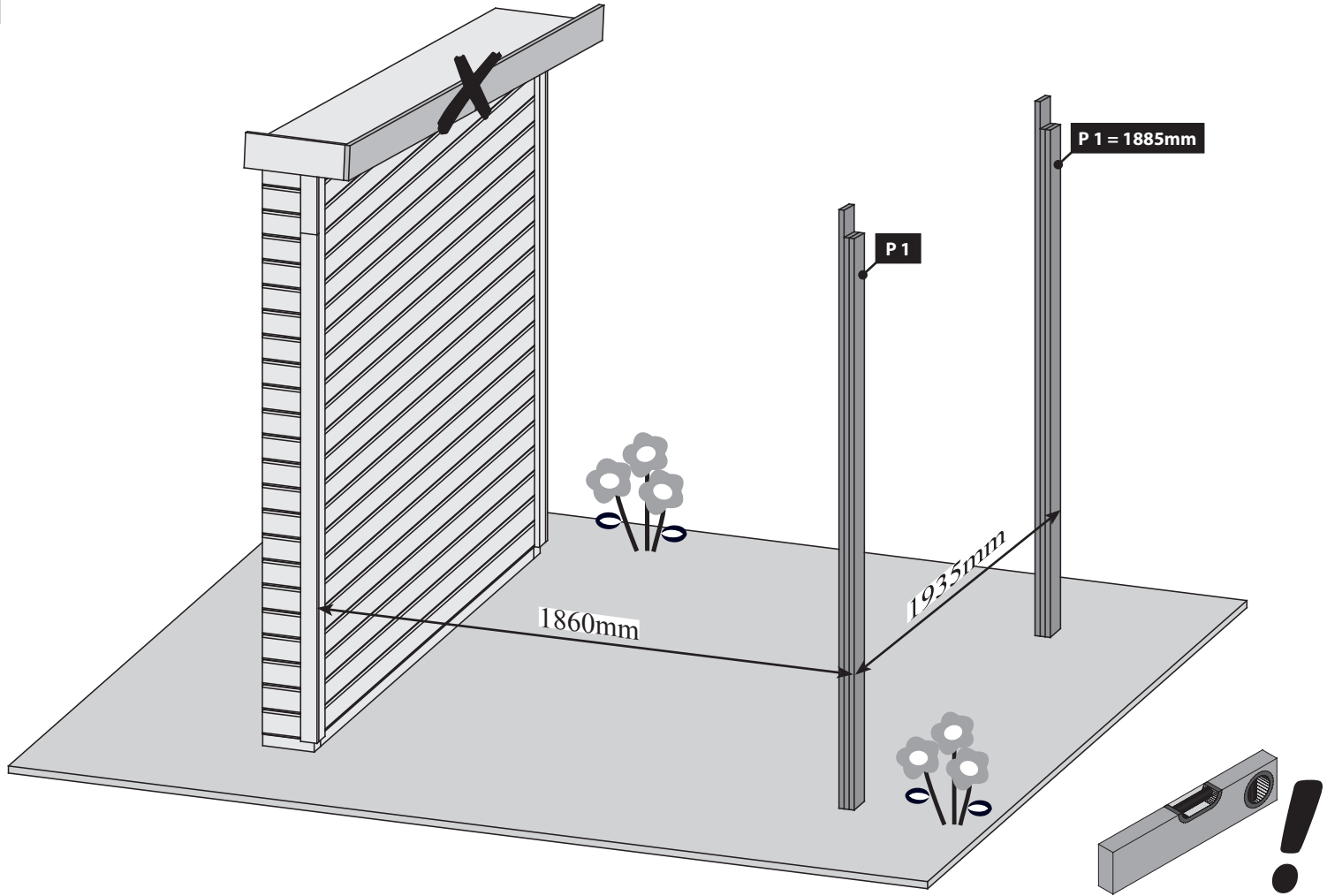

03

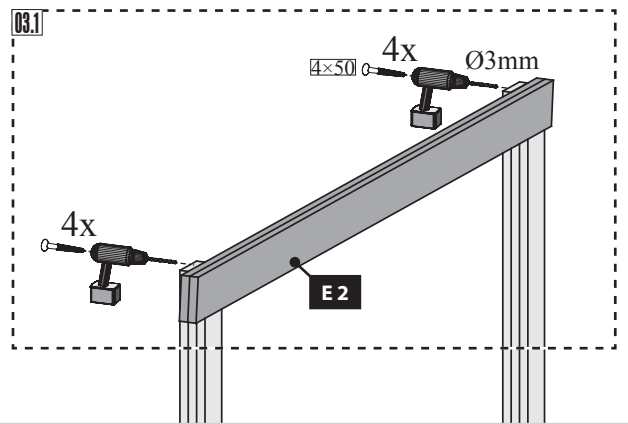
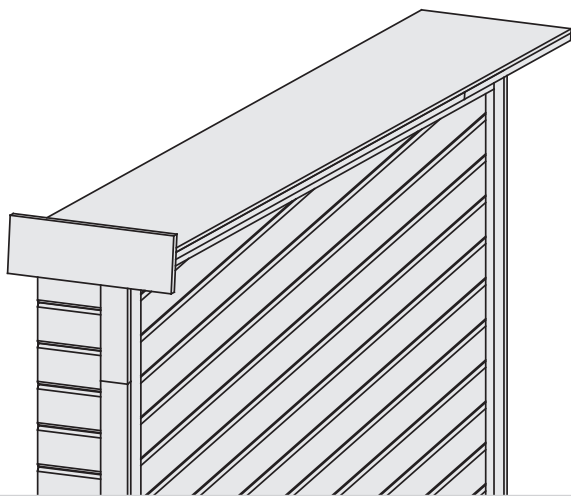

03.1

**B** → ←

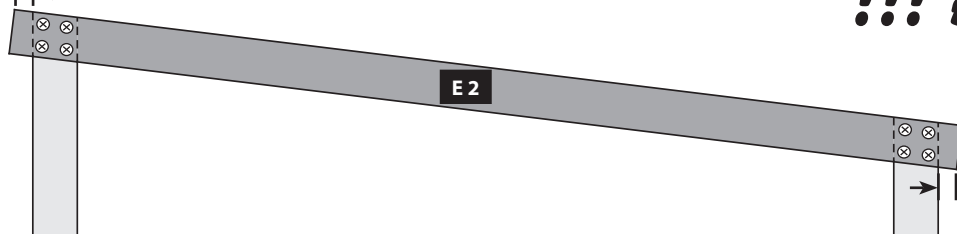

**!!! A=B !!!**

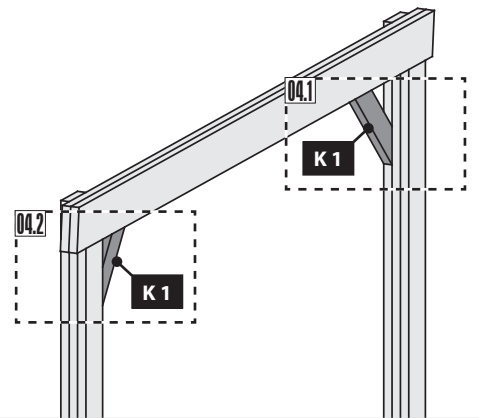
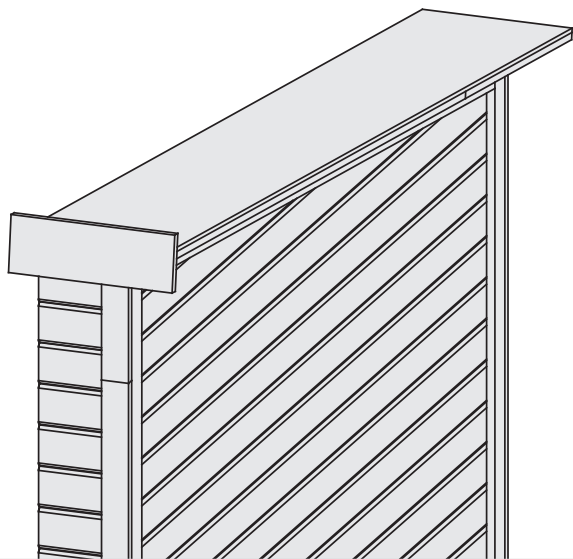

04.1

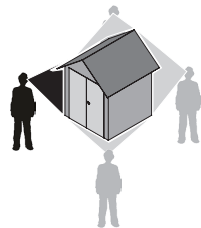
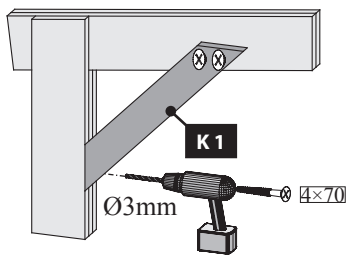

04.2

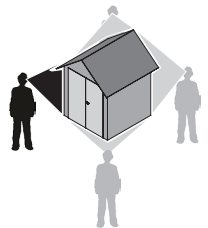
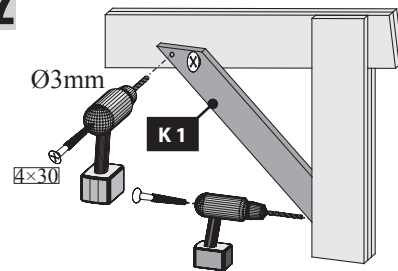

05

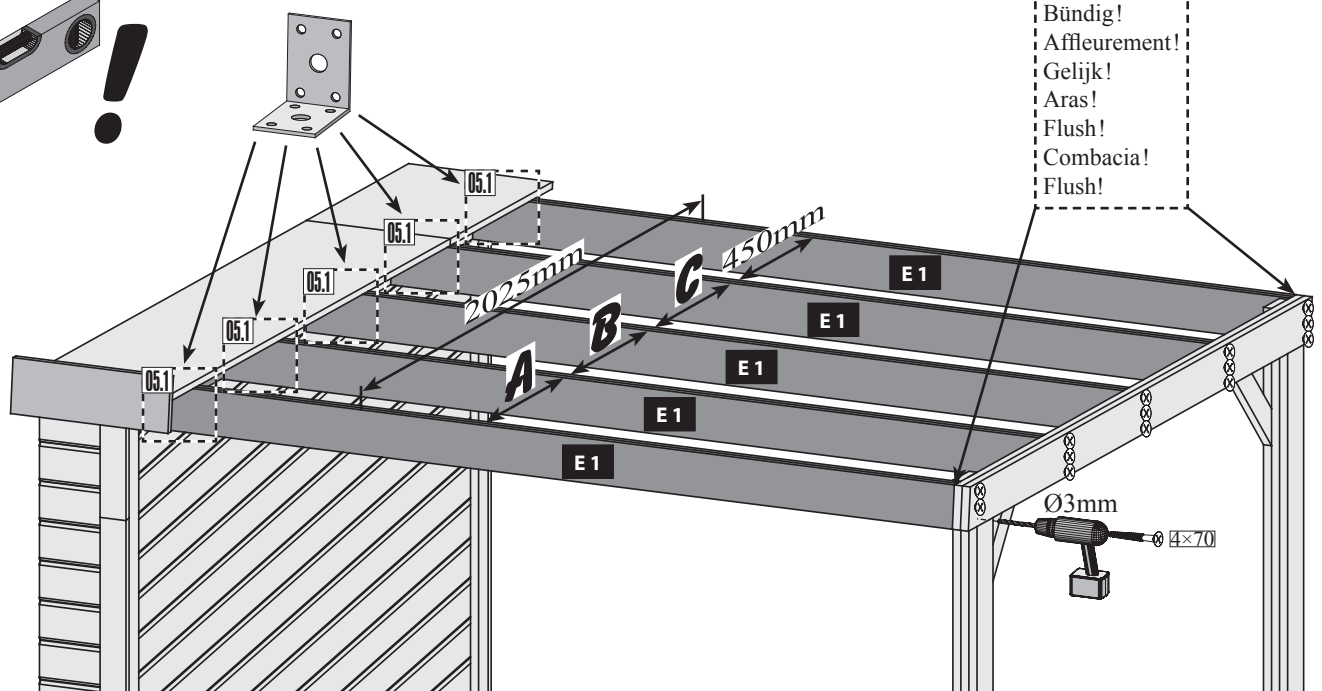
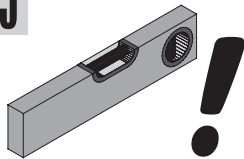

05.1

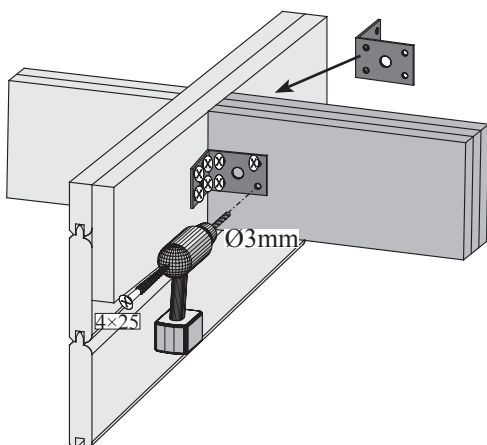

**!!! A=B=C !!!**

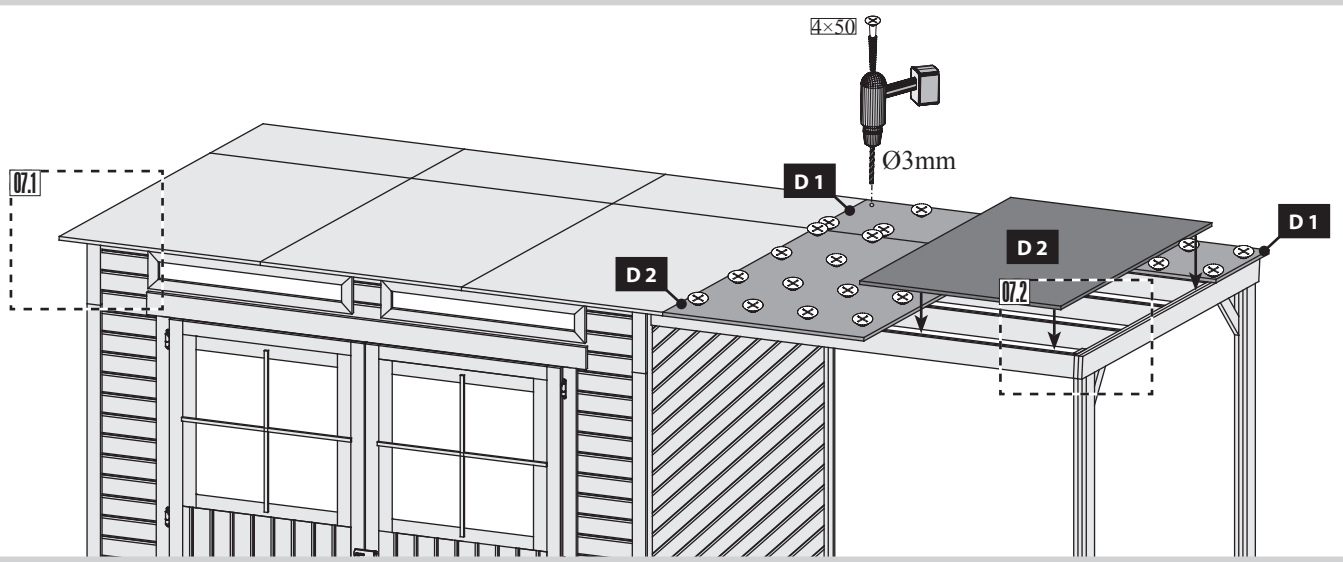
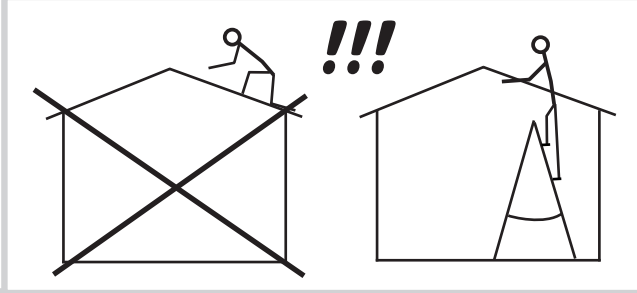
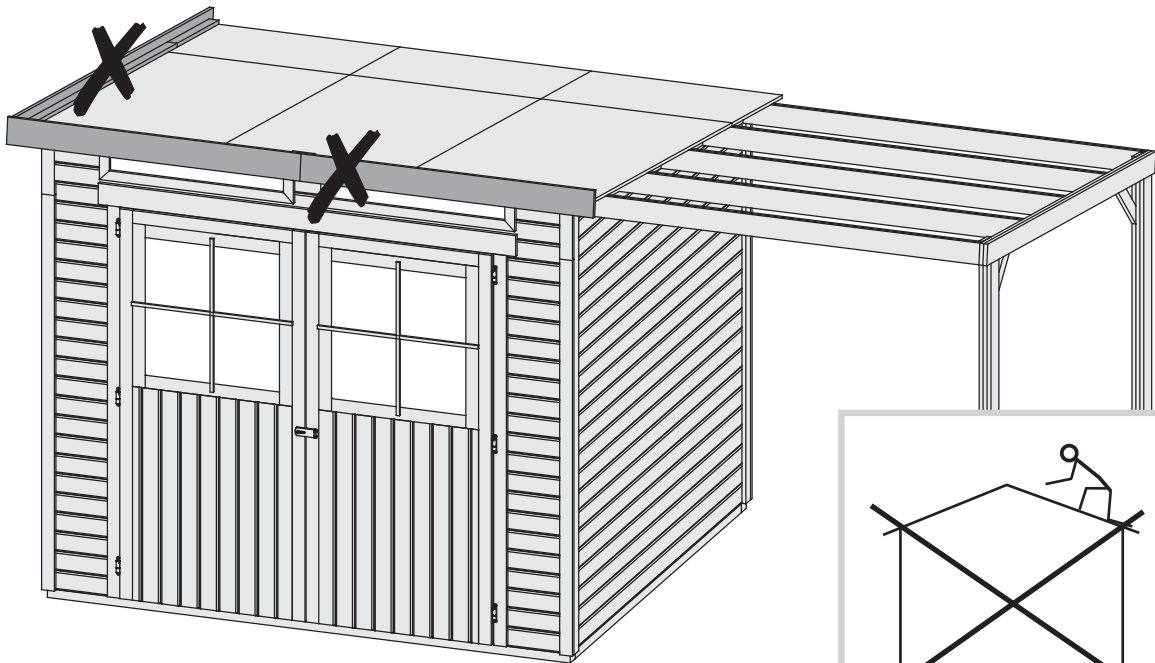

57735 57854 68213

Aufbauanleitung  
 notice de montage  
 Building Instructions  
 montagehandleiding  
 Instrucciones de construcción  
 Istruzioni per il montaggio  
 Service-Hotline: +49 421 38693 33

07.1

! ca 122mm  
ca 130mm

07.2

ca 130mm

Bündig!  
Affleurement!  
Gelijk!  
Aras!  
Flush!  
Combacia!  
Flush!

57744 57860 68215

Aufbauanleitung  
 notice de montage  
 Building Instructions  
 montagehandleiding  
 Instrucciones de construcción  
 Istruzioni per il montaggio  
 Service-Hotline: +49 421 38693 33







07.1

! ca 72mm  
ca 130mm

07.2

ca 130mm

Bündig!  
Affleurement!  
Gelijk!  
Aras!  
Flush!  
Combacia!  
Flush!

 Die Eindeckung muss spätestens nach 2 Monaten durch ein geeignetes Produkt ergänzt werden  
 De vervanging mag niet later zijn dan twee maanden aangevuld met een geschikt product  
 The replacement must be no later than two months supplemented by a suitable product  
 Le remplacement ne doit pas être plus tard deux mois complétés par un produit adapté  
 El reemplazo debe ser no más tarde de dos meses complementan con un producto adecuado  
 La sostituzione deve essere entro e non oltre due mesi completate da un prodotto adatto  
 Pokrytí střechy musí být nejpozději po 2 měsících nahrazeno vhodným produktem.

Für die dauerhafte Eindeckung empfehlen wir die selbstklebende Bitumendachbahn aus unserem Sortiment. Die erforderliche Menge für dieses Produkt (Haus mit Schleppdach) ist 3 Rollen (Artikelnummer 68589).

08

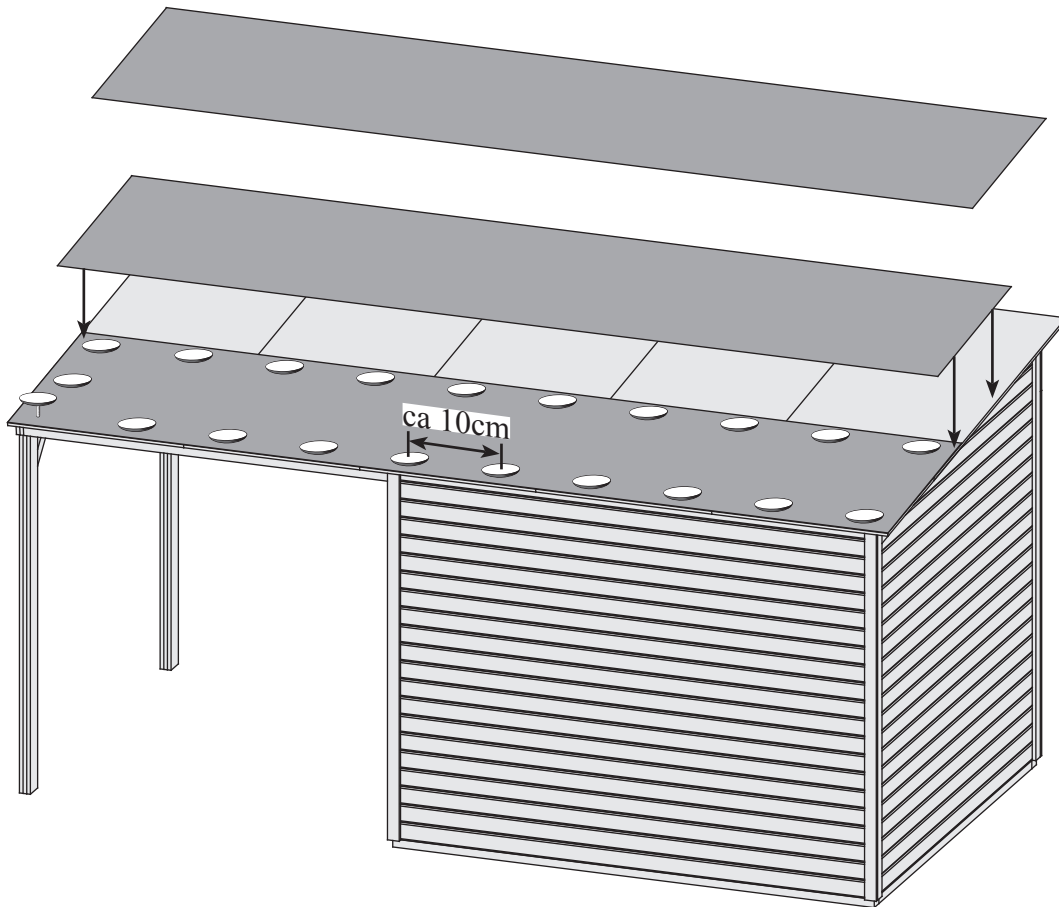
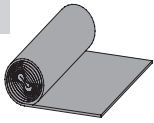

09

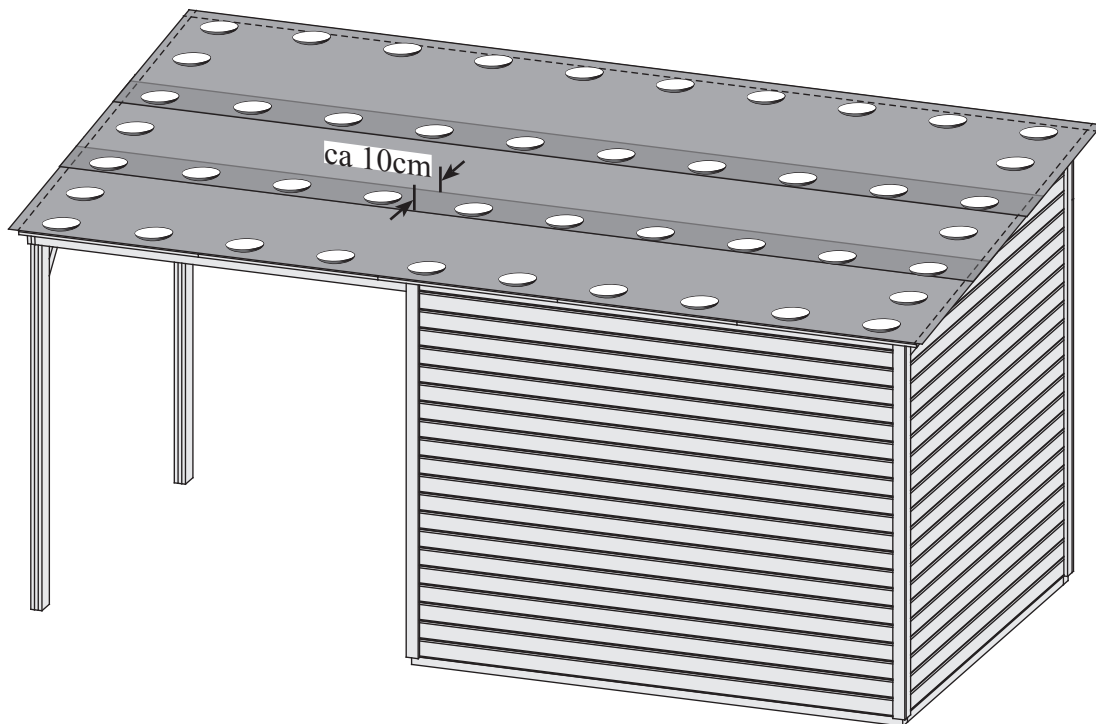
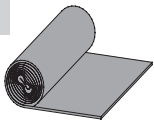

10

1x

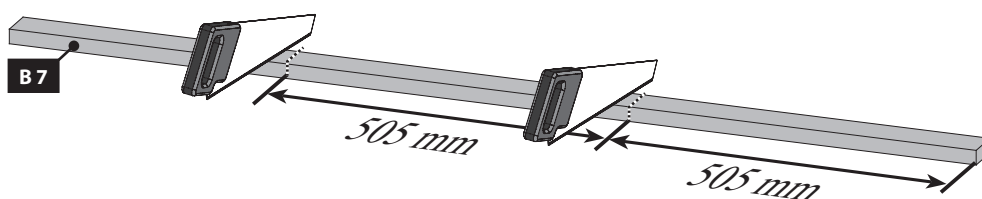



11

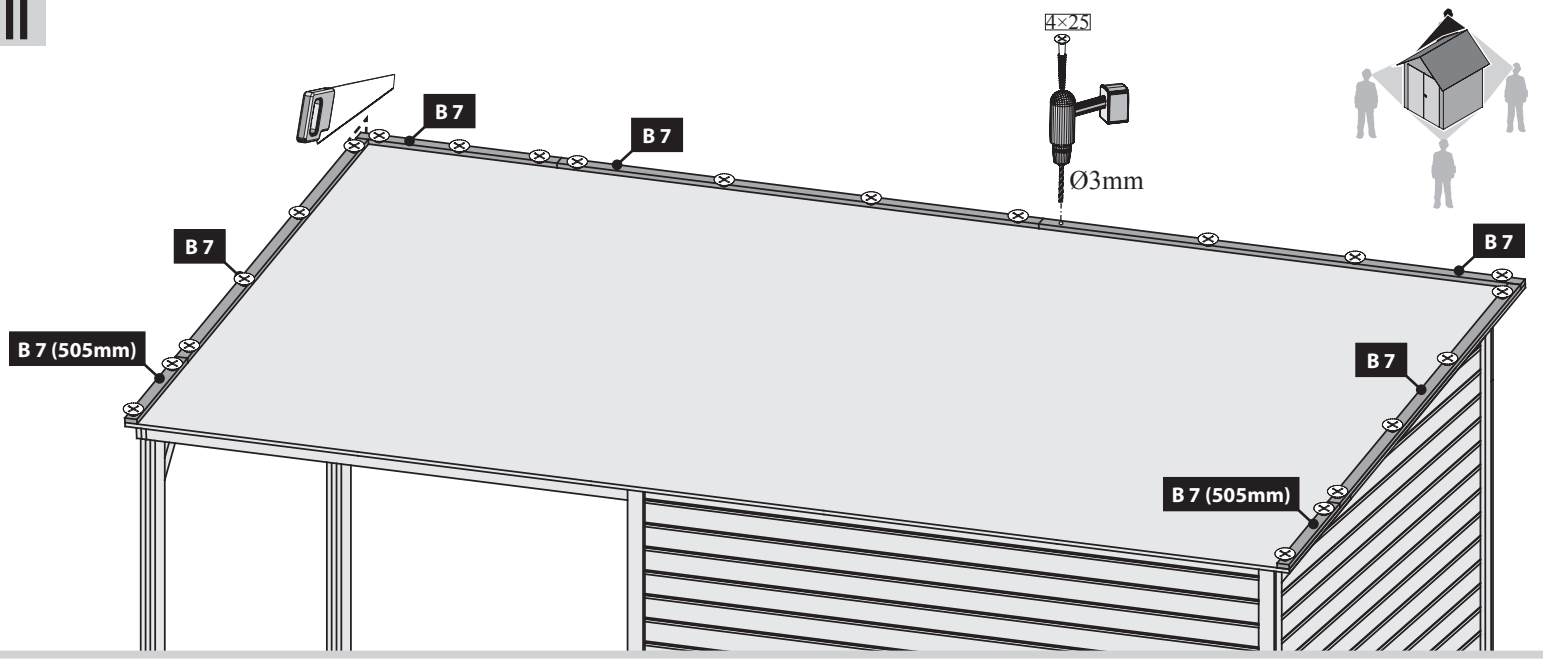

12

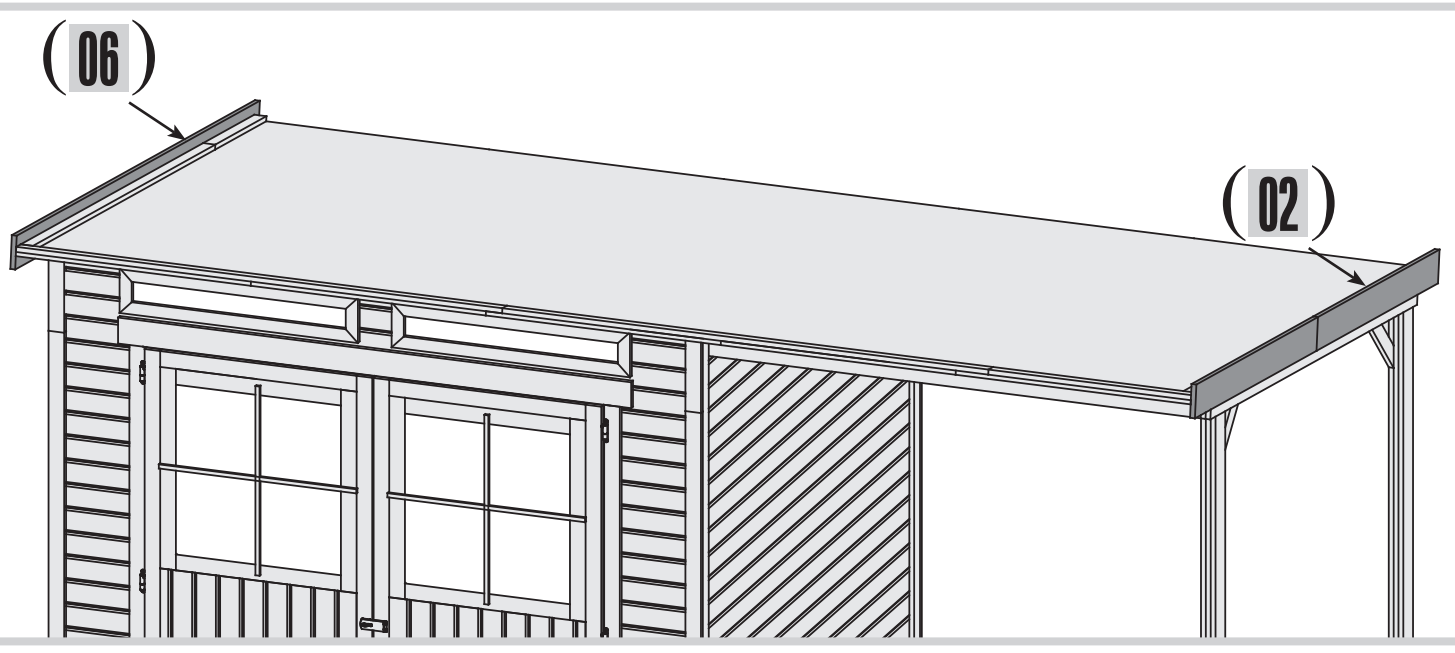

13

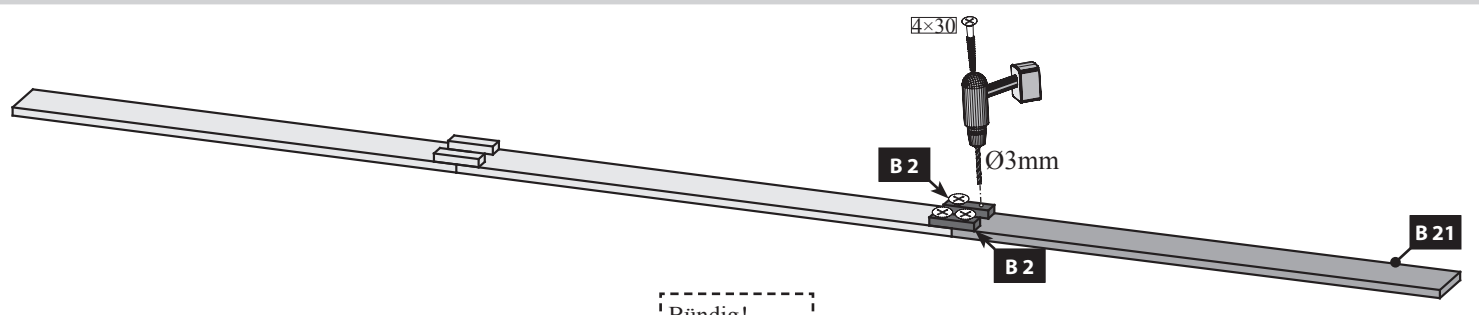

Bündig!  
Affleurement!  
Gelijk!  
Aras!  
Flush!  
Combacia!  
Flush!

14

