

# 64993

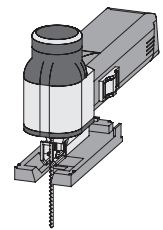
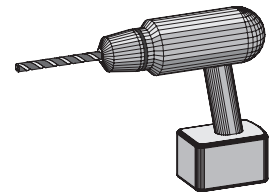
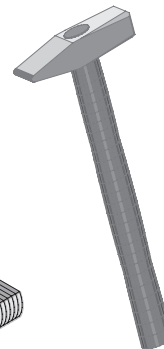
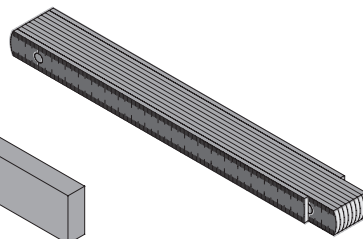
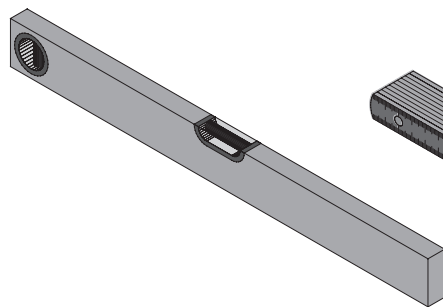
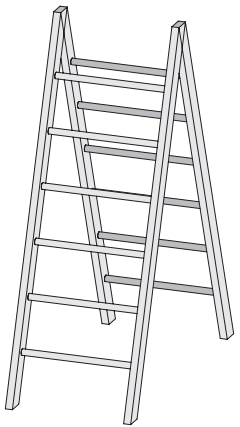
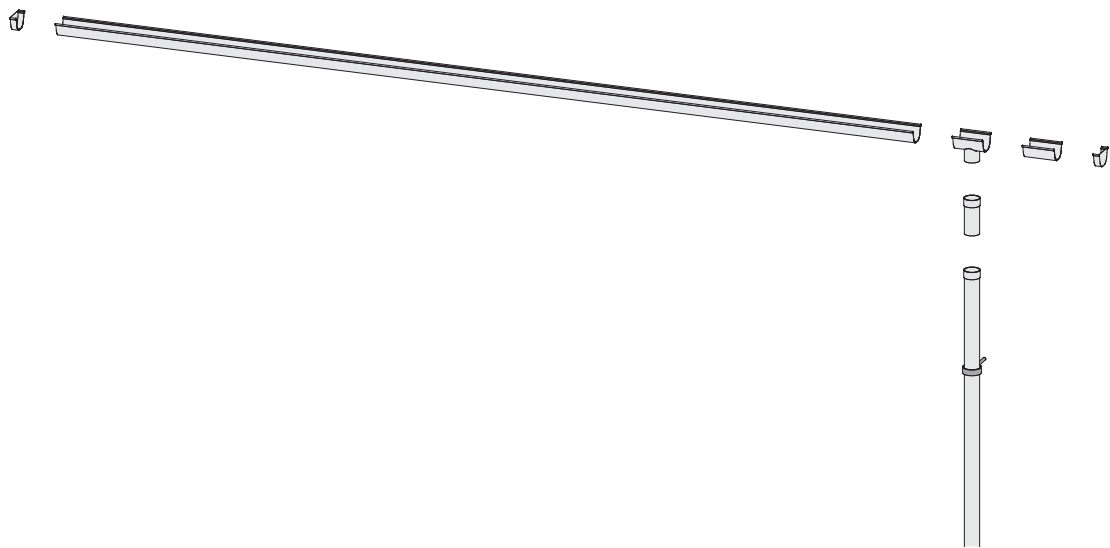

 **Aufbauanleitung**

 **notice de montage**

 **Building Instructions**

 **montagehandleiding**

 **Instrucciones de construcción**

 **Istruzioni per il montaggio**

 **Service-Hotline: +49 421 38693 33**



Vergleichen Sie zuerst die Materialliste mit Ihrem Paketinhalt! Bitte haben Sie Verständnis, dass Beanstandungen nur im nicht aufgebauten Zustand bearbeitet werden können!



Commencez par comparer la liste du matériel avec le contenu de votre paquet! Sachez que nous traitons uniquement les réclamations concernant le matériel à l'état non monté!



First compare the list of materials with your package contents! Please understand that complaints can be processed in the non-built status only!



Vergelijk eerst de lijst van materialen met de inhoud van uw pakket! Reclamaties kunnen alleen in behandeling worden genomen zolang de onderdelen nog niet zijn gemonteerd!



En primer lugar, compare la lista de material con el contenido del paquete. Rogamos entienda que las reclamaciones sólo pueden ser tramitadas antes de montar el objeto!



Confrontate questa distinta materiali prima con il contenuto del pacchetto! Vi preghiamo di comprendere che eventuali reclami possono essere accolti solo prima del montaggio!



64993

1 x R1	11cm	ID 62218
1 x R2	3m	ID 62211
1 x R3		ID 62216

2 x R4		ID 62213 /69902
1 x R5		ID 62214
3 x R6		ID 62215

1 x R8		ID 63489
--------	--	----------

1 x R9		ID 63490
--------	--	----------

	Kleber für Dachrinne
	Colle pour gouttière
	Glue for gutter
	Lijm voor goot
	Pegamento para el canal
Colla per canale	
1 x	ID 62217

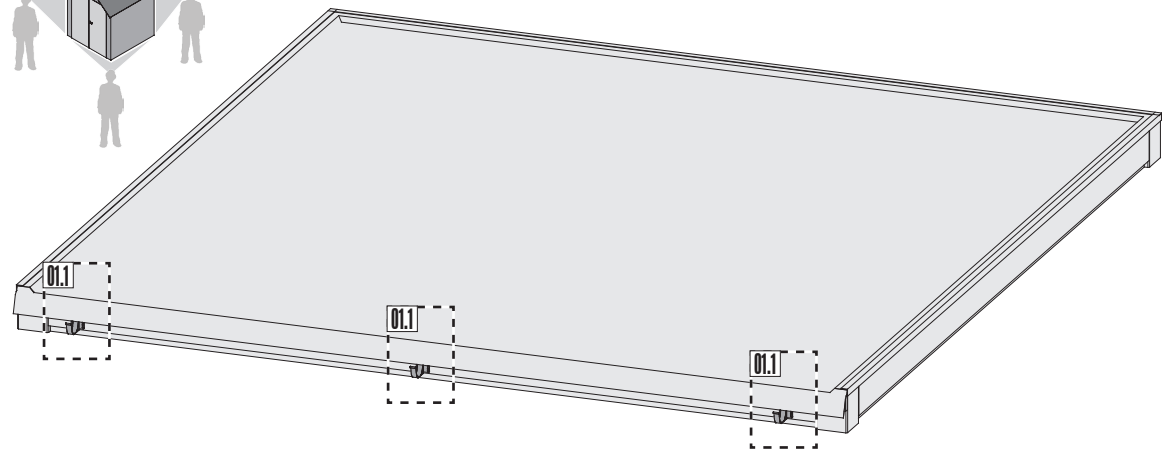
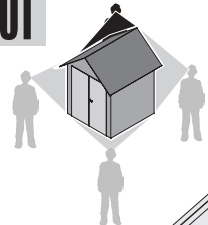
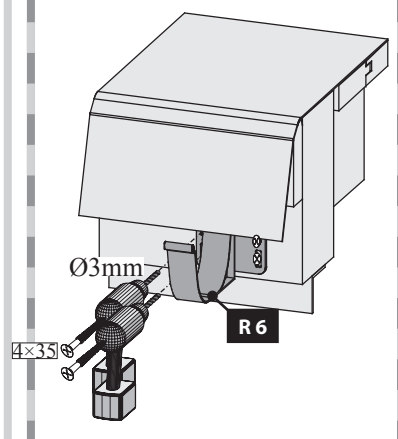
**01****01.1****02**

-  Kleber für Dachrinne
-  Colle pour gouttière
-  Glue for gutter
-  Lijm voor goot
-  Pegamento para el canal
-  Colla per canale

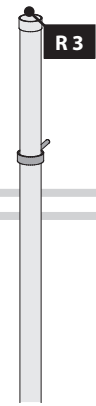
**03**