

## 80505

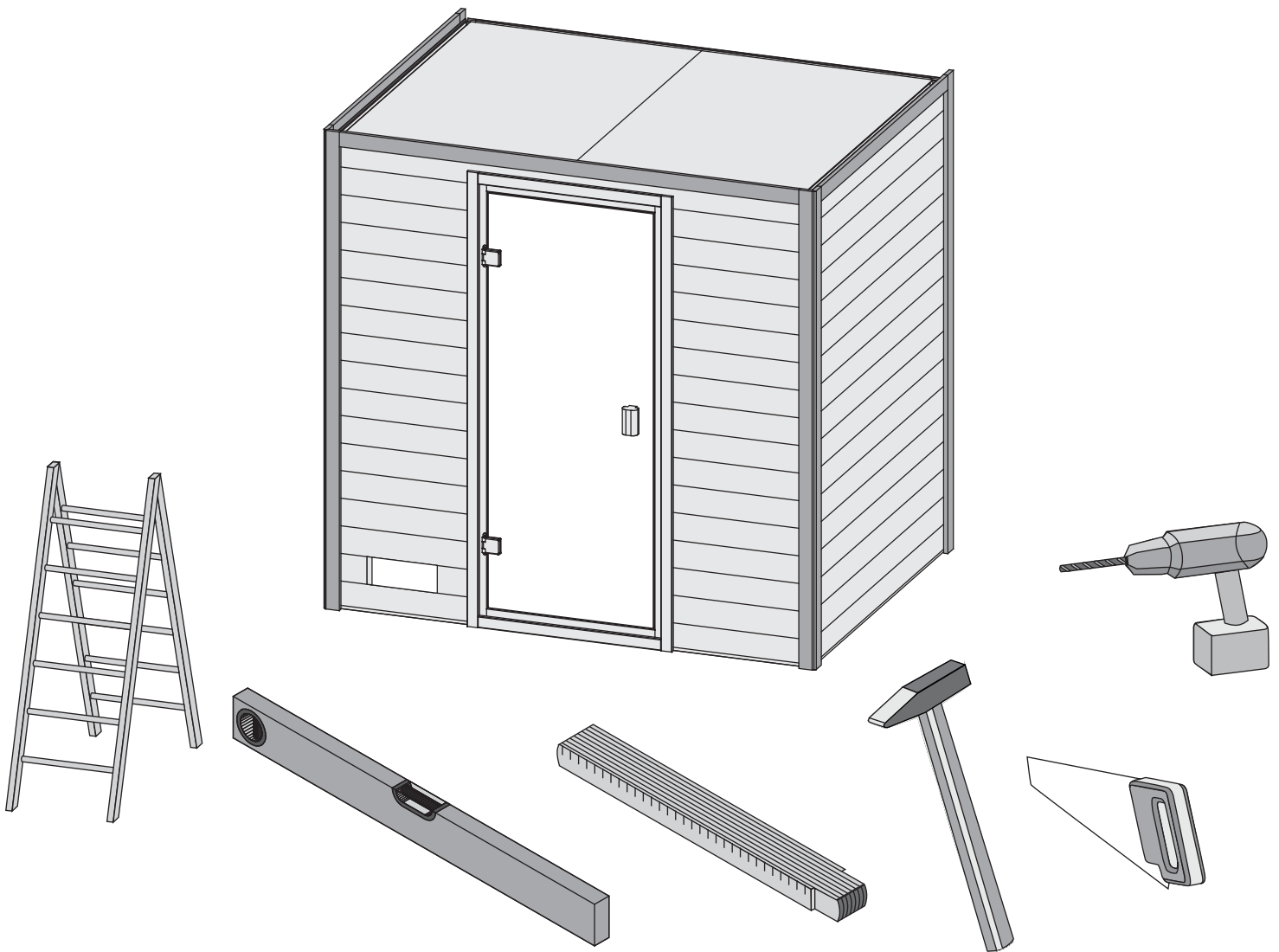

**Aufbauanleitung**



**notice de montage**



**Building Instructions**



**montagehandleiding**



**Instrucciones de construcción**



**Istruzioni per il montaggio**



**Montážní návod**



**Service-Hotline: +49 421 38693 33**



Vergleichen Sie zuerst die Materialliste mit Ihrem Paketinhalt! Bitte haben Sie Verständnis, dass Beanstandungen nur im nicht aufgebauten Zustand bearbeitet werden können!



En primer lugar, compare la lista de material con el contenido del paquete. Rogamos entienda que las reclamaciones sólo pueden ser tramitadas antes de montar el objeto!



Nejprve přezkontrolujte obsah balení podle materiálového listu! Mějte pochopení pro to, že případnou reklamaci se můžeme zabývat pouze tehdy, když díly nebudou smontované! Za pomoci tohoto seznamu můžete jednotlivé díly přiřadit k montážnímu návodu.



Vergelijk eerst de lijst van materialen met de inhoud van uw pakket! Reclamaties kunnen alleen in behandeling worden genomen zolang de onderdelen nog niet zijn gemonteerd!



First compare the list of materials with your package contents! Please understand that complaints can be processed in the non-built status only!



Commencez par comparer la liste du matériel avec le contenu de votre paquet! Sachez que nous traitons uniquement les réclamations concernant le matériel à l'état non monté!



Confrontate questa distinta materiali prima con il contenuto del pacchetto! Vi preghiamo di comprendere che eventuali reclami possono essere accolti solo prima del montaggio!

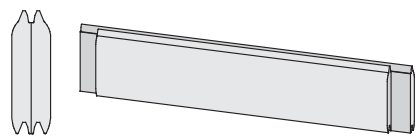
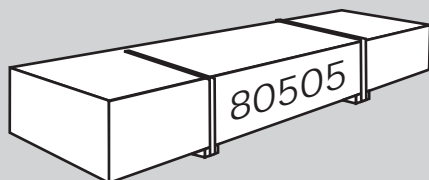

34 x A1	1380 x 121 x 38mm	ID 26573
17 x A2	1881 x 121 x 38mm	ID 21429

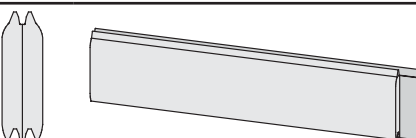

1 x A3	135 x 121 x 38mm	ID 80223
16 x A4	545 x 121 x 38mm	ID 21868

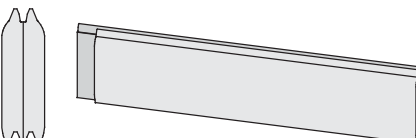

15 x A5	545 x 121 x 38mm	ID 21876
---------	------------------	----------

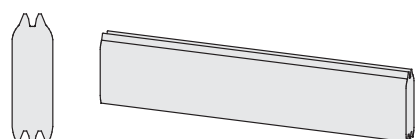

1 x A6	135 x 121 x 38mm	ID 80224
--------	------------------	----------

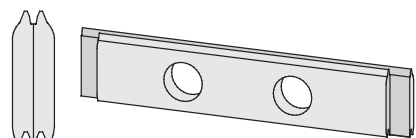

1 x A7	1881 x 121 x 38mm	ID 21864
--------	-------------------	----------

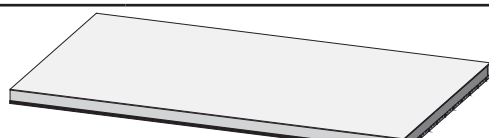

2 x M1	1338 x 918 x 55mm	ID 26575
--------	-------------------	----------

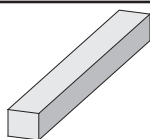

1 x B1	1920 x 20 x 3mm	ID 20799
2 x B2	1810 x 90 x 16mm	ID 71513
5 x B3	2000 x 58 x 17mm	ID 48541
2 x B4	250 x 45 x 18mm	ID 26716
2 x B5	550 x 45 x 18mm	ID 26717
2 x B6	800 x 45 x 18mm	ID 24796
4 x B7	1809 x 45 x 18mm	ID 21831
2 x B8	1845 x 45 x 18mm	ID 18106
1 x B9	300 x 95 x 18mm	ID 19130
4 x B10	480 x 95 x 18mm	ID 20930
4 x B11	565 x 95 x 18mm	ID 15498
2 x B12	800 x 58 x 28mm	ID 15493
4 x B13	1806 x 36 x 36mm	ID 66692

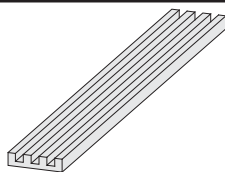

1 x E1	1820 x 110 x 26mm	ID 26480
--------	-------------------	----------

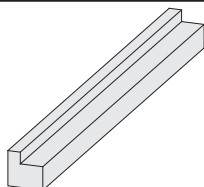

2 x E2	250 x 45 x 45mm	ID 3863
2 x E3	555 x 45 x 45mm	ID 40301

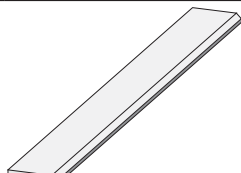

4 x E4	2000 x 58 x 17mm	ID 48545
--------	------------------	----------

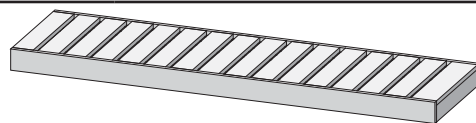

1 x L1	1810 x 250 x 90mm	ID 26576
1 x L2	1810 x 550 x 90mm	ID 43994

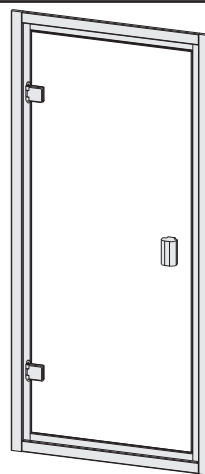



1 x D1	1796 x 815 x 38mm	ID 66683
--------	-------------------	----------

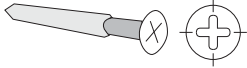

20 x	4 x 30mm	ID 3686
60 x	4 x 35mm	ID 3687
350 x	4 x 40mm	ID 21925
30 x	4 x 50mm	ID 3688
30 x	4 x 70mm	ID 3689
25 x	4,5 x 80mm	ID 9204
20 x	6 x 60mm	ID 14014
20 x	6 x 80mm	ID 47558
80 x	6 x 90mm	ID 26715

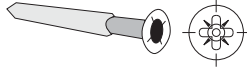
		
20 x	4 x 30 mm	ID 3686
60 x	4 x 35 mm	ID 3687
350 x	4 x 40 mm	ID 21925
30 x	4 x 50 mm	ID 3688
30 x	4 x 70 mm	ID 3689
25 x	4,5 x 80 mm	ID 9204
20 x	6 x 60 mm	ID 14014
20 x	6 x 80 mm	ID 47558
80 x	6 x 90 mm	ID 26715

		
50 x	4,5 x 40 mm	ID 26285

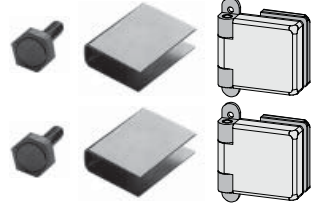

		
60 x		ID 26116

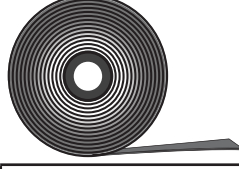

		
1 x		ID 26496

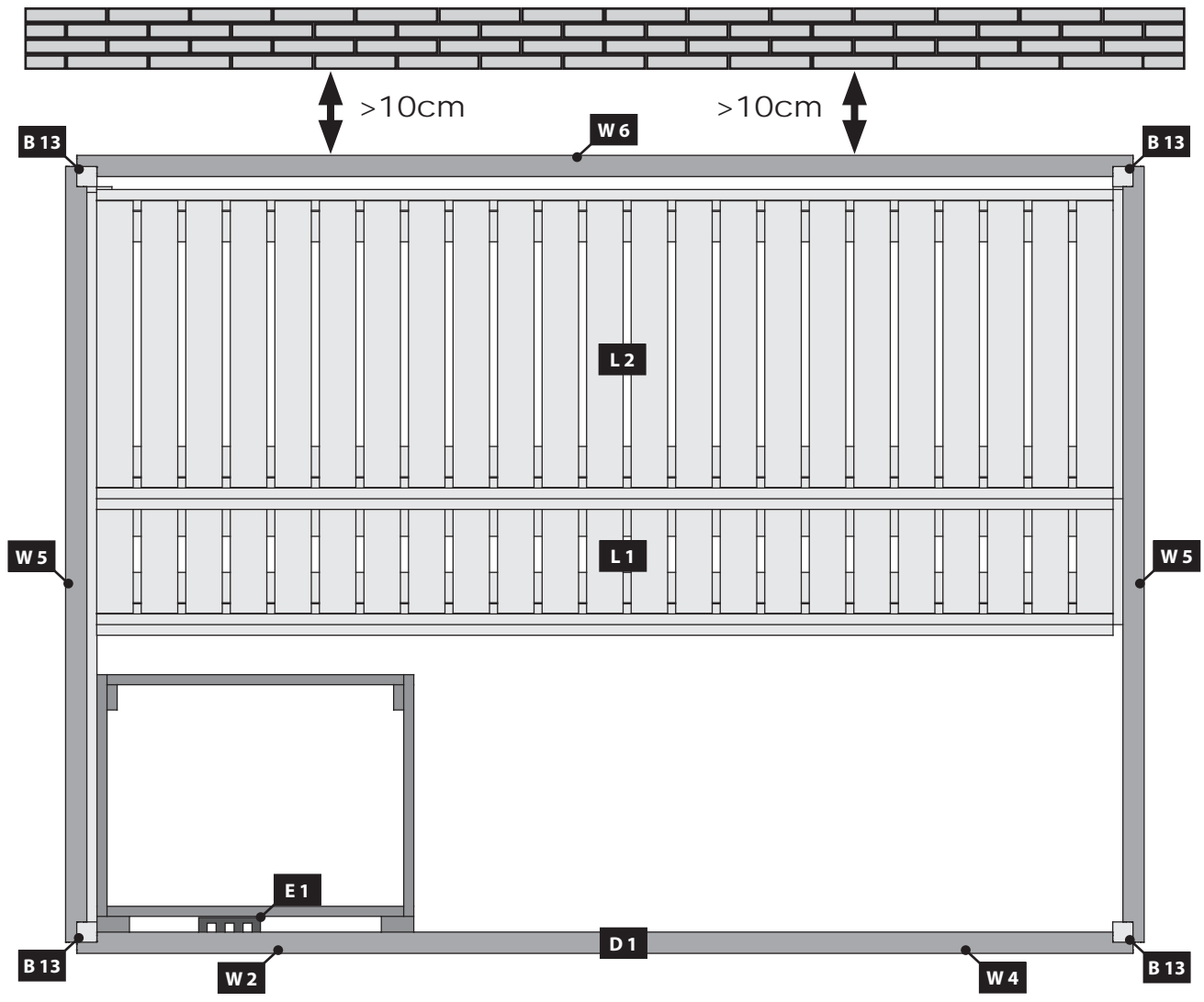
		
1 x		ID 14025

-  Draufsicht
-  bovenaanzicht
-  Top view
-  vue de dessus
-  vista desde arriba
-  vista dall'alto
-  pùdorys



 Leim! Achten Sie auf die gleiche Höhe  
 Glue! Look for the same height  
 Colle! Faites attention à la même hauteur

 Lijm! Besteed aandacht aan de dezelfde hoogte  
 Pegamento! Prestar atención a la misma altura  
 Colla! Prestare attenzione alla stessa altezza

 Klíž! Dávejte pozor na stejnou výšku

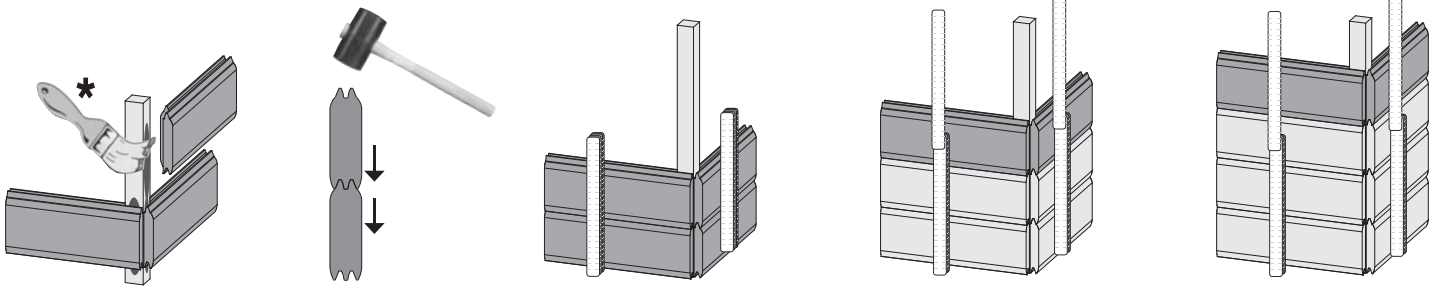

01

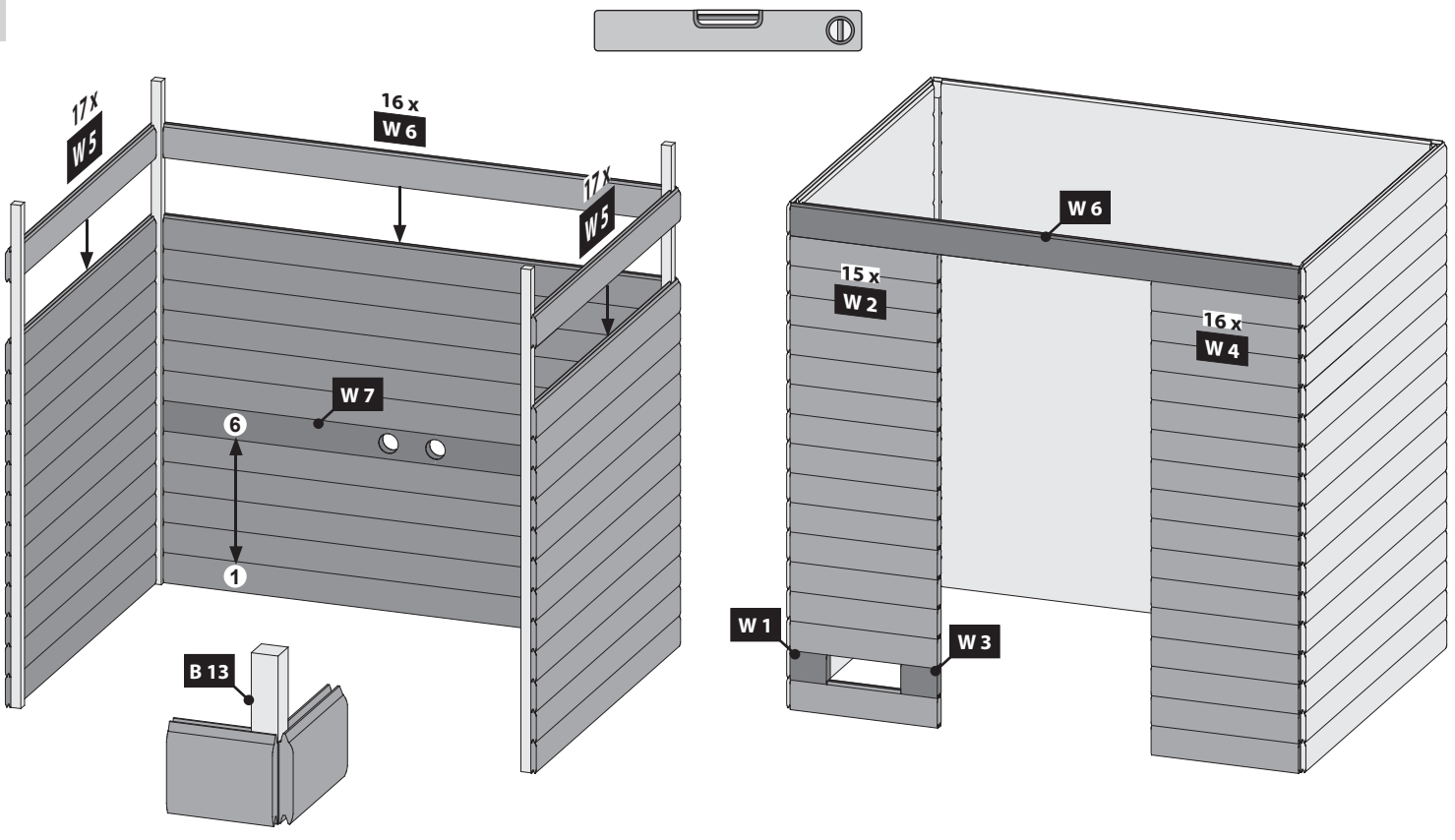

02

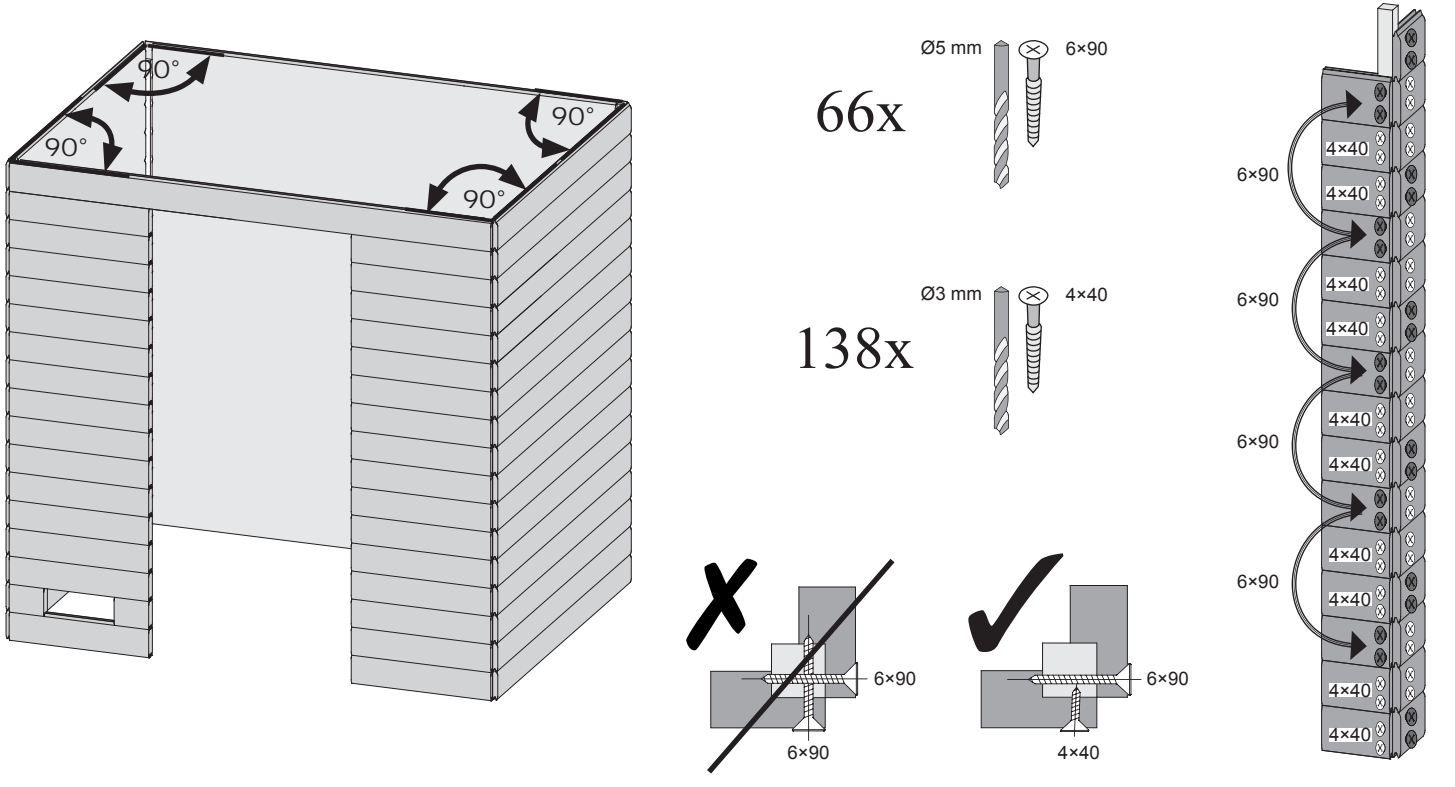

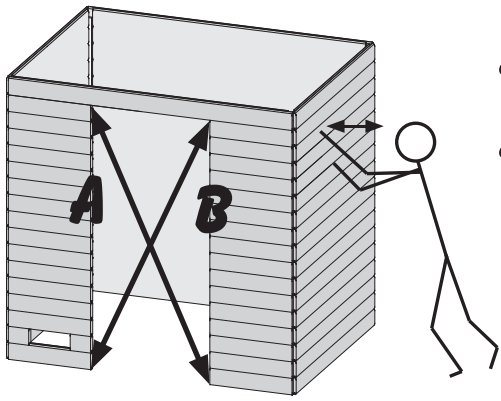

**!!! A=B !!!**  
**!!! C=D !!!**

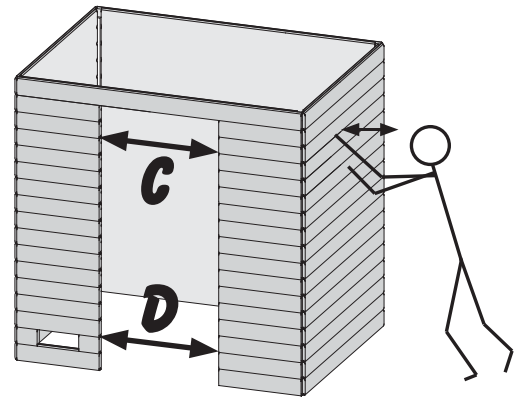

**03**

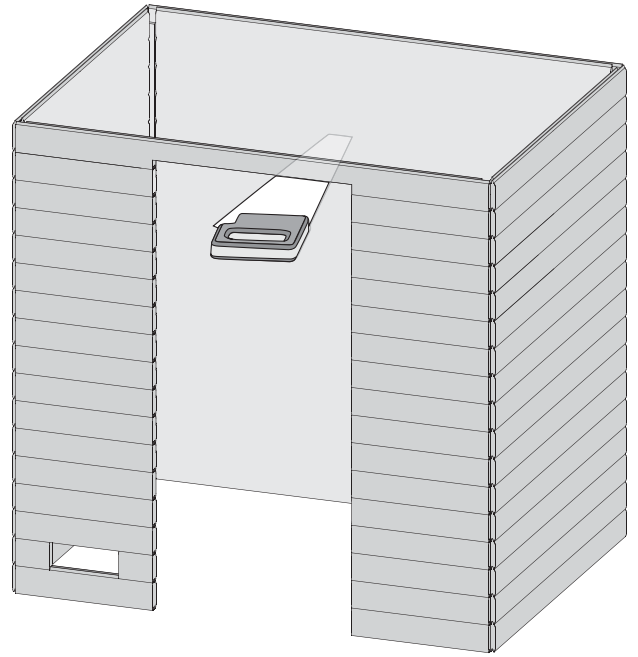
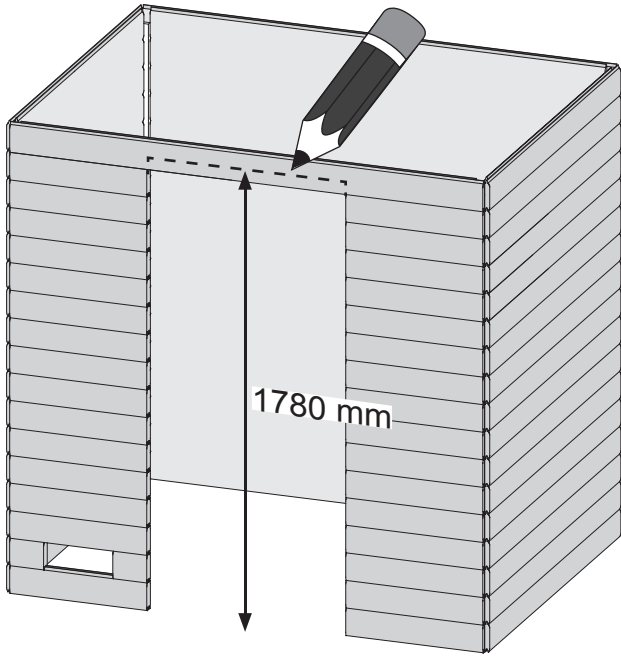

- Einbau Glastür
- Montage porte en verre
- Installation of glass door

- Montage van de glazen deur
- Montaje de la puerta de cristal

- Installazione portello di vetro
- Sauna Instalace dveře

**!!! 01 — 03 !!!**

**04**

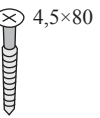
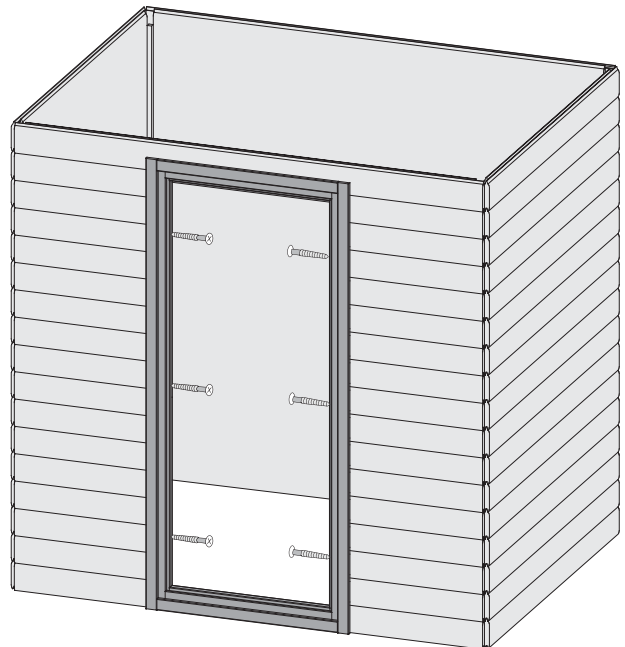
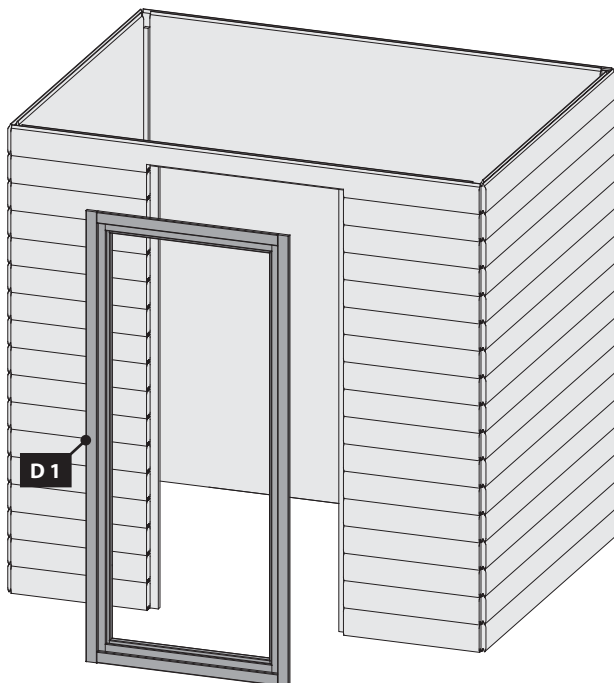

05

2x

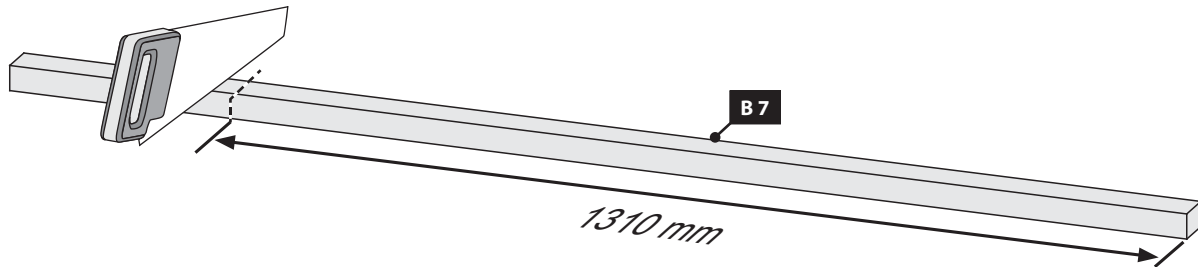

06

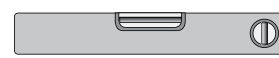

Ø3mm

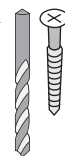

4x40

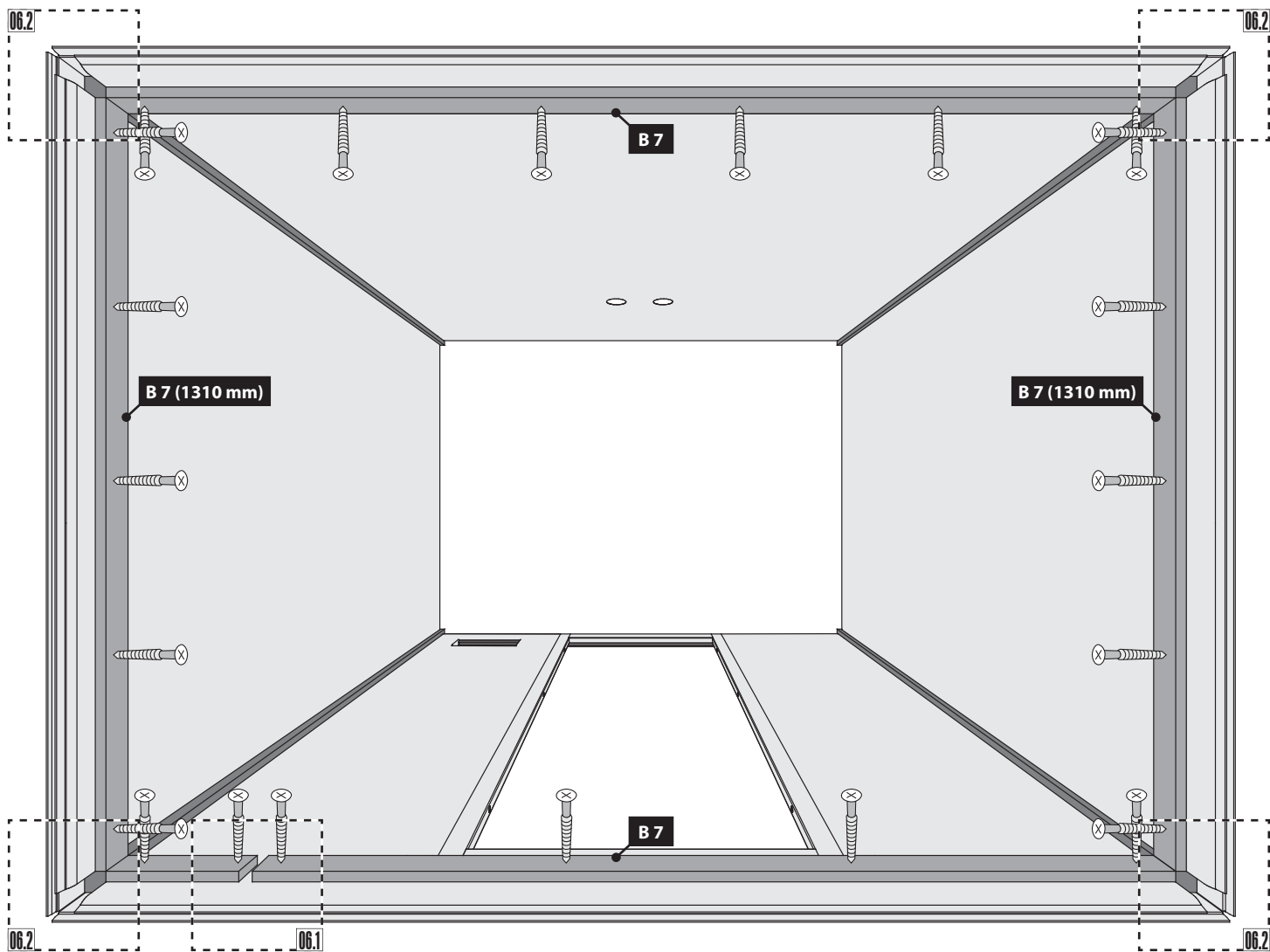

06.1

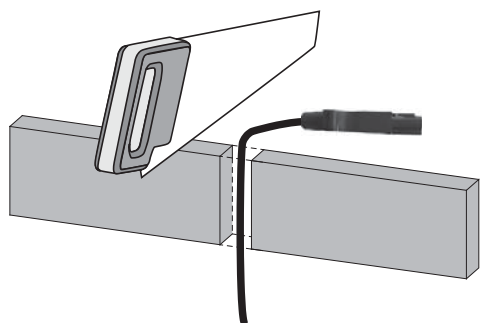

06.2

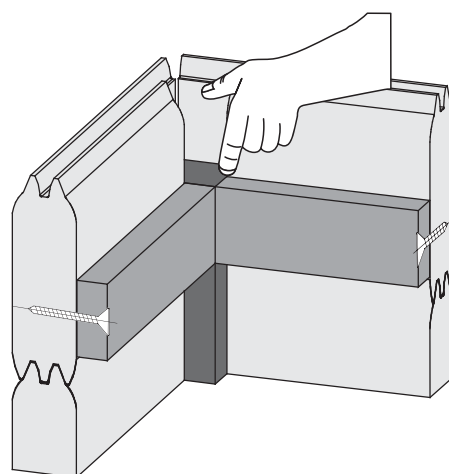

- Bündig!
- Affleurement!
- Gelijk!
- Aras!
- Flush!
- Combacia!
- Flush!



07 2x

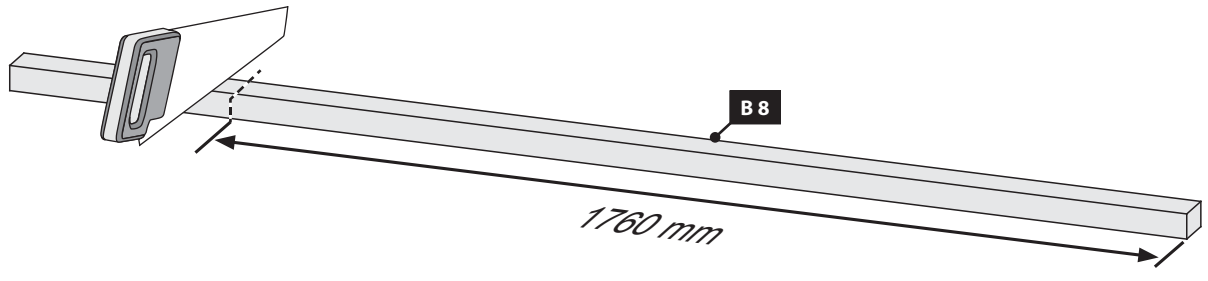

08

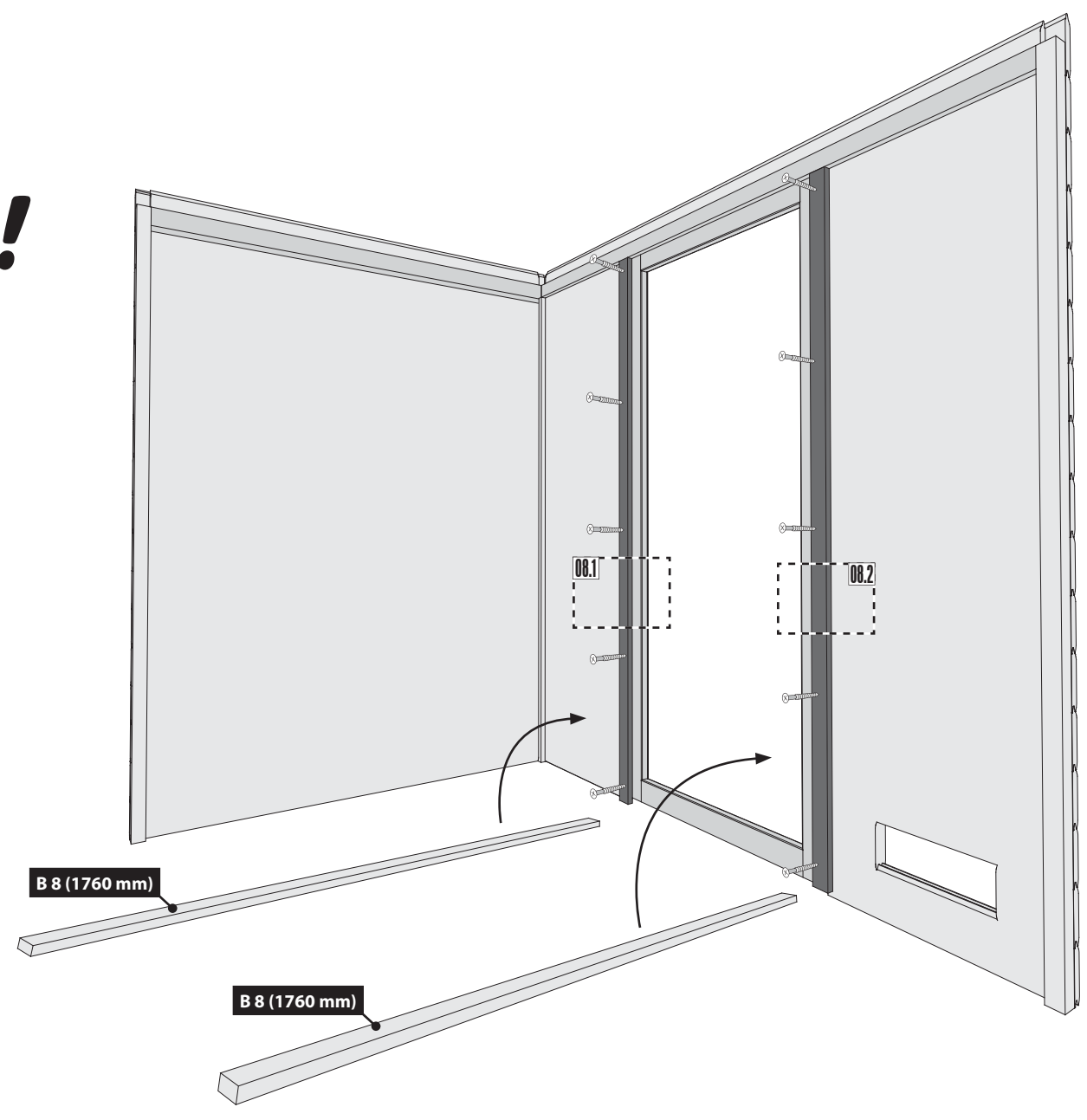

08.1

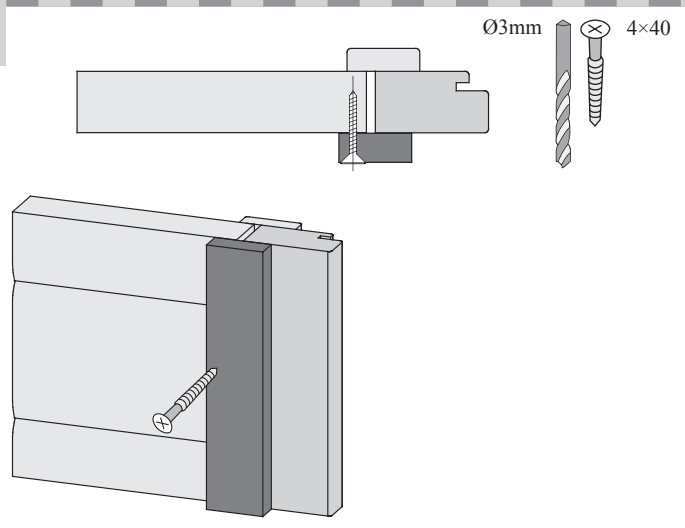

08.2

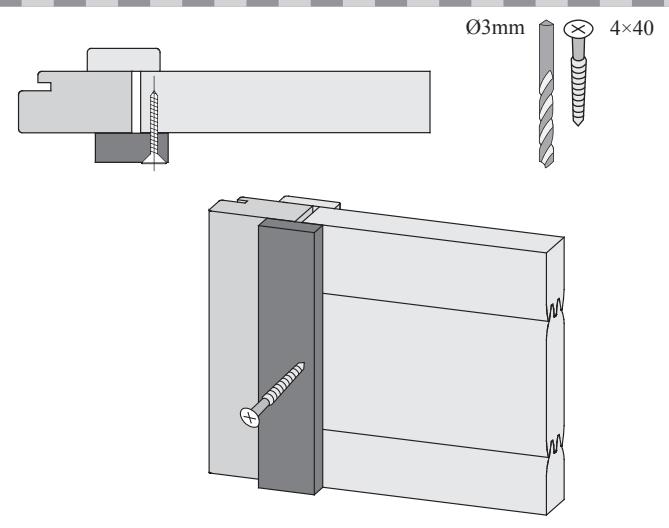

09 2x

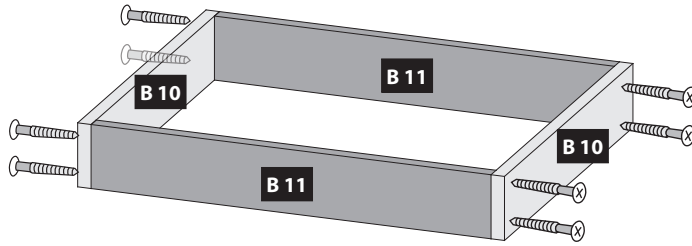
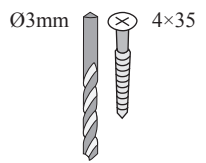

10 a

-  Nur bei 9 kW-Ofen
-  Seulement 9 kW chauffe
-  Only 9 kW heater
-  Slechts 9 kW heater
-  Sólo calentador de 9 kW
-  Solo riscaldamento 9 kW
-  Pouze topné těleso 9 kW

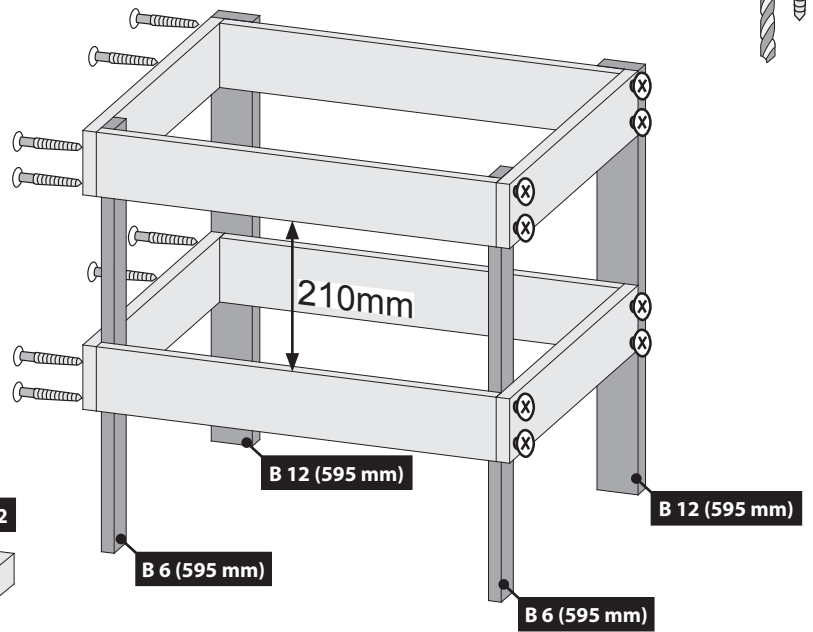
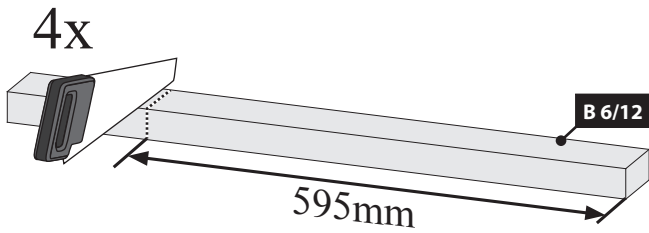
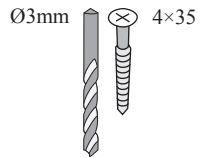

10 b

-  Bei allen anderen Öfen
-  Pour tous les autres fours
-  For all other furnaces
-  Voor alle andere ovens
-  Para todos los otros hornos
-  Per tutti gli altri tipi di forni
-  U všech ostatních pecích

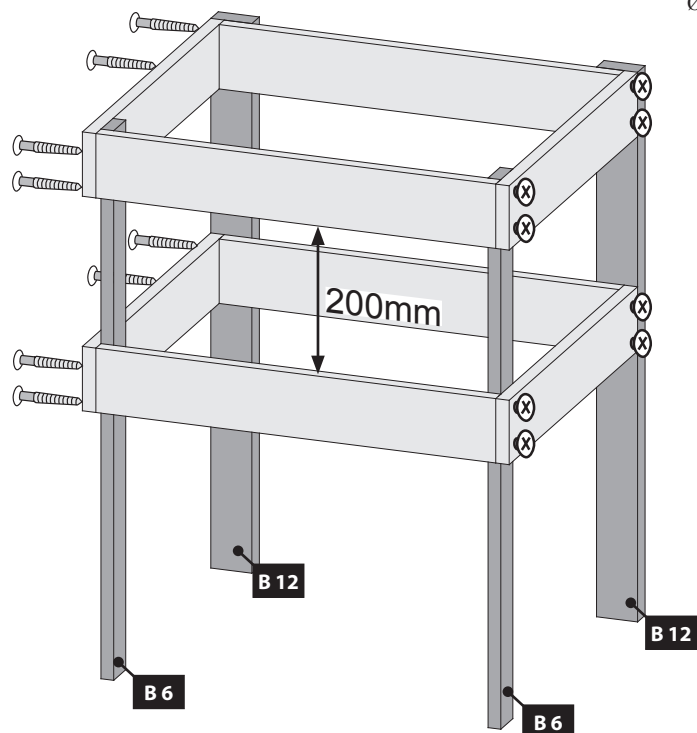
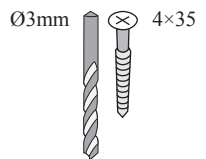



11

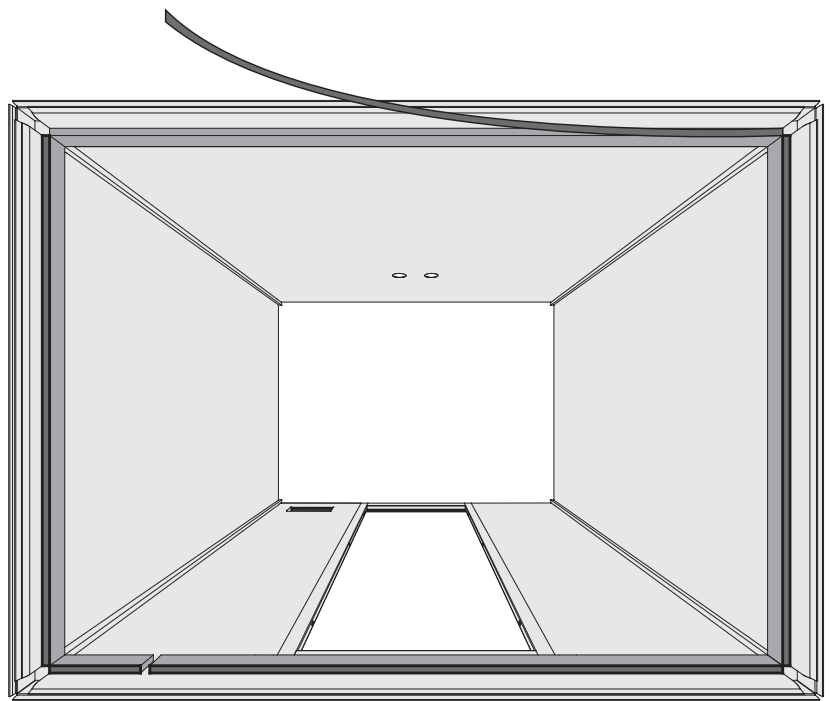
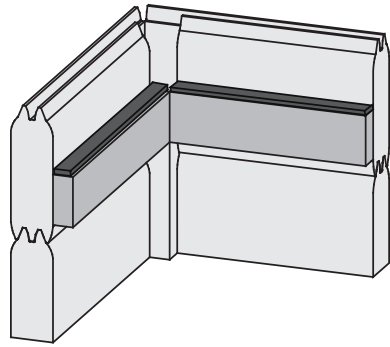
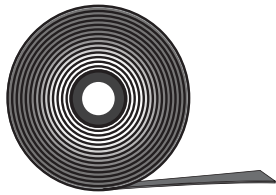

12

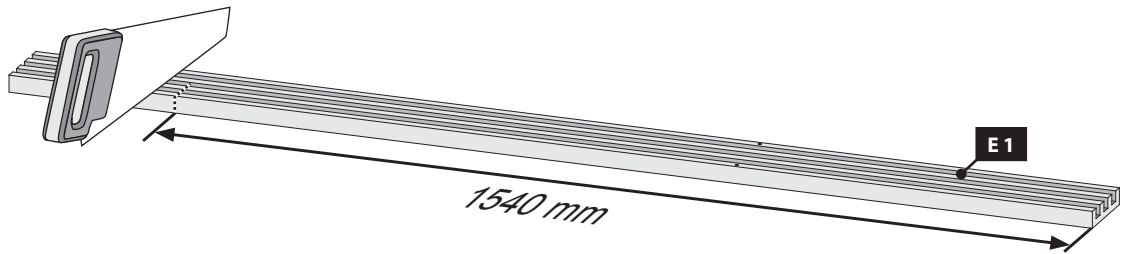

13

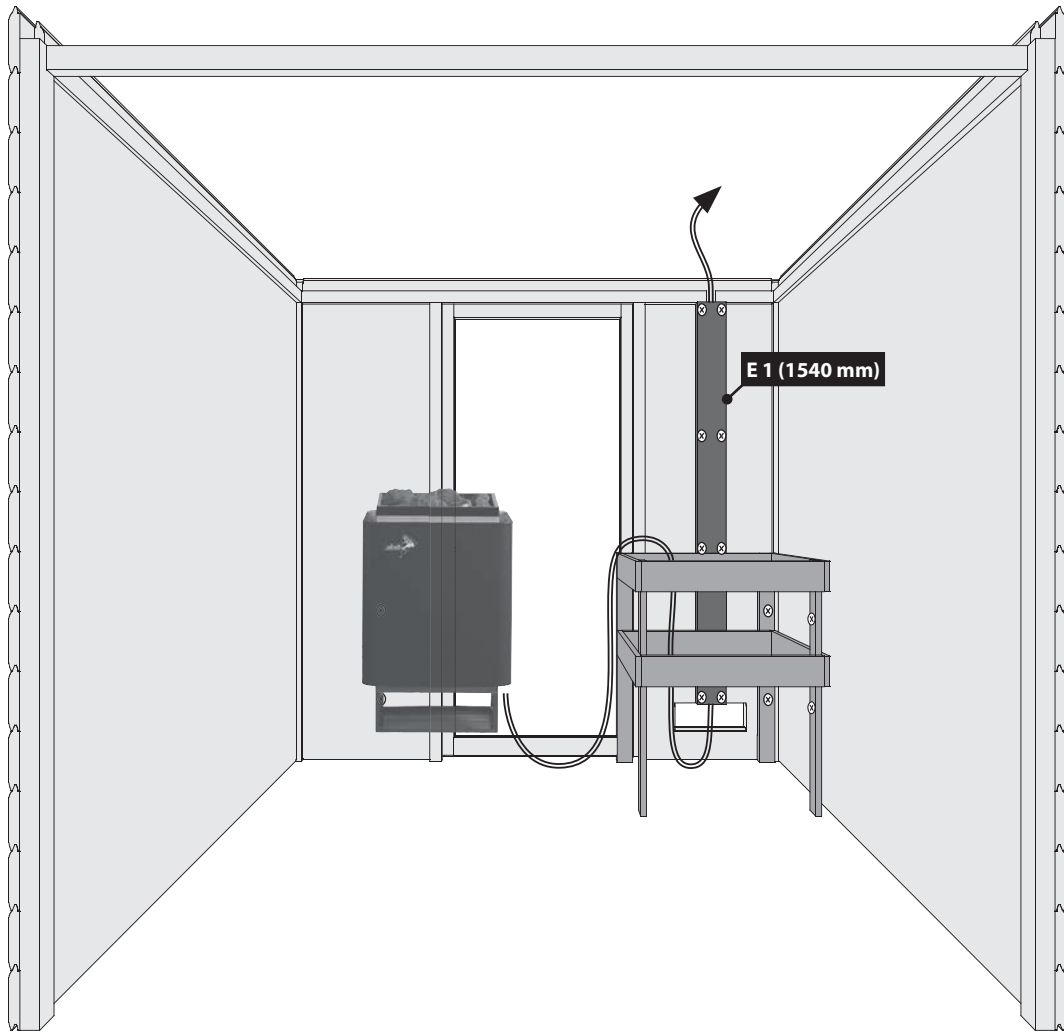

Ø3mm 4x50

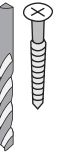

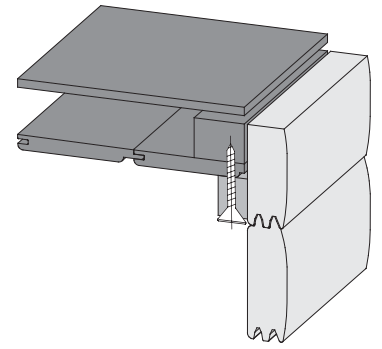
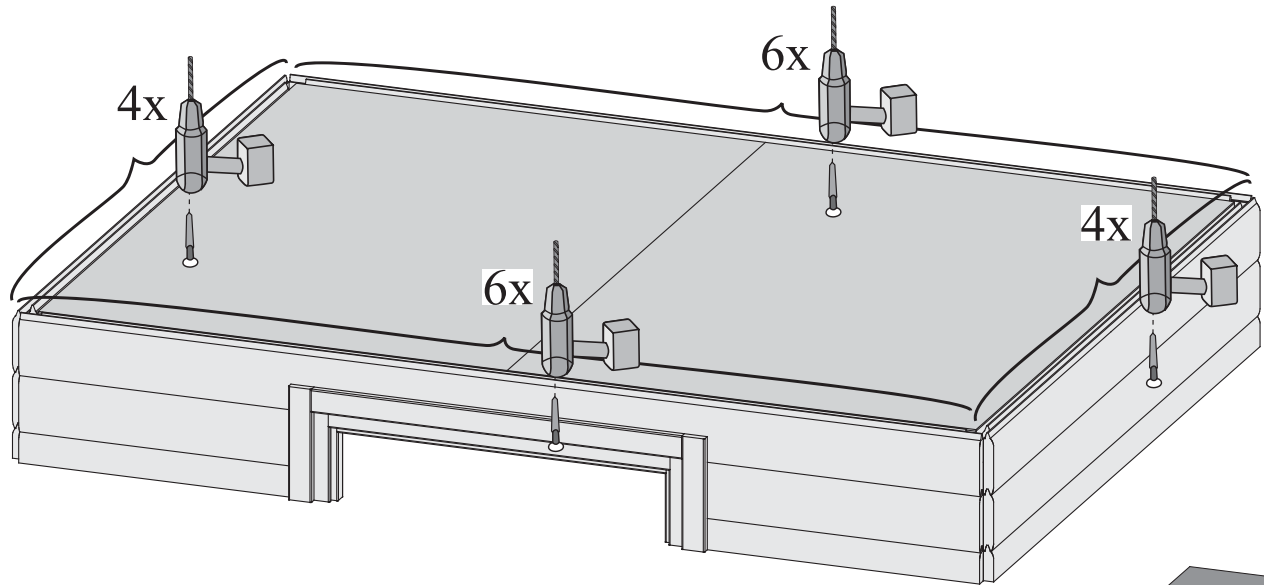
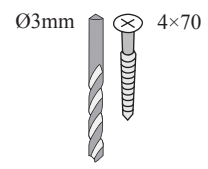
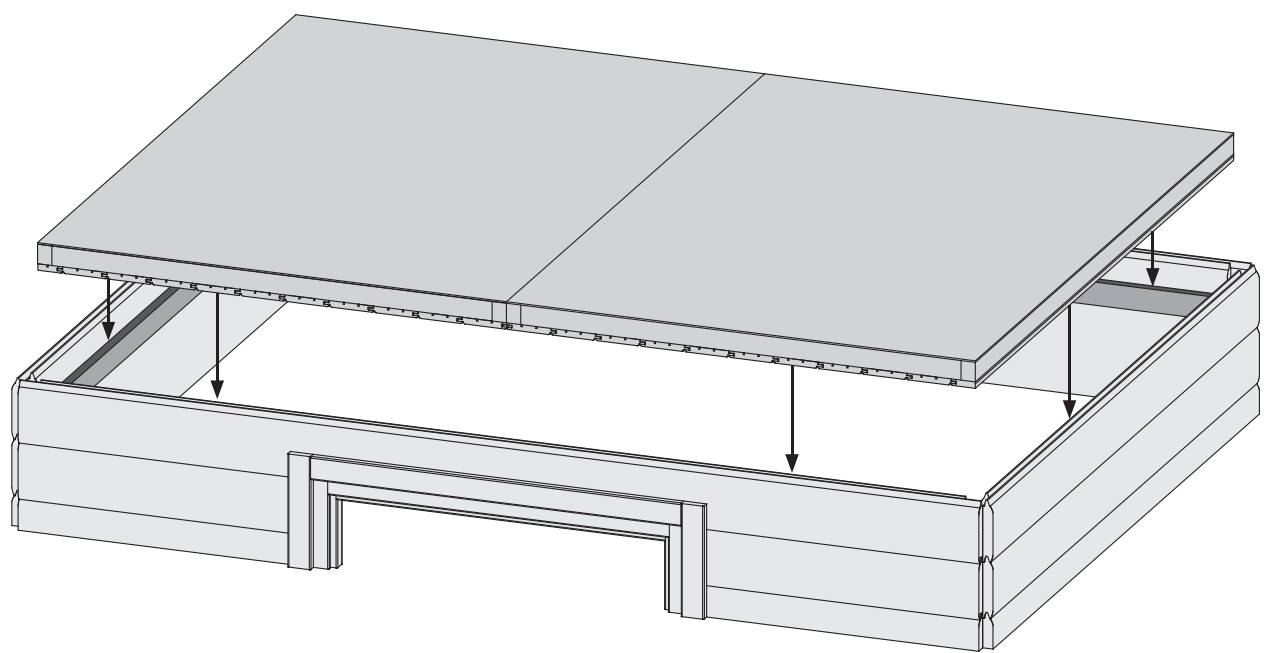
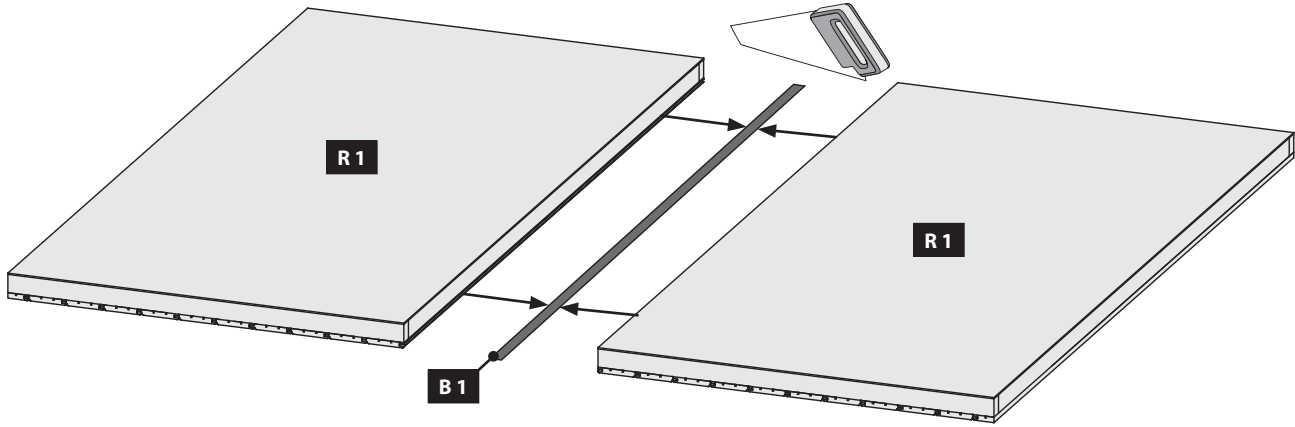

16 2x

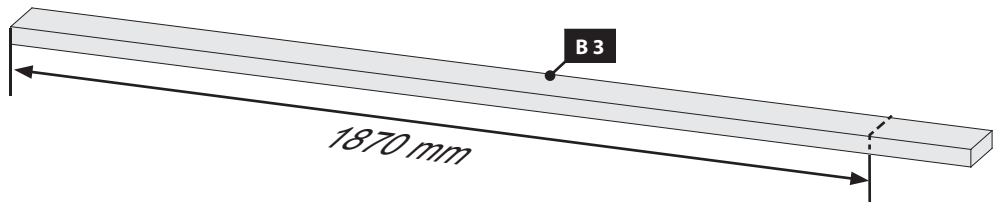

17 4x

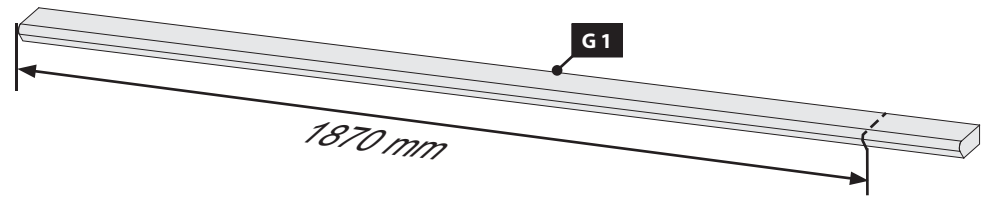

18

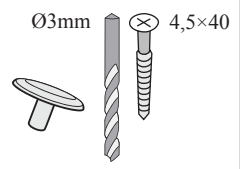
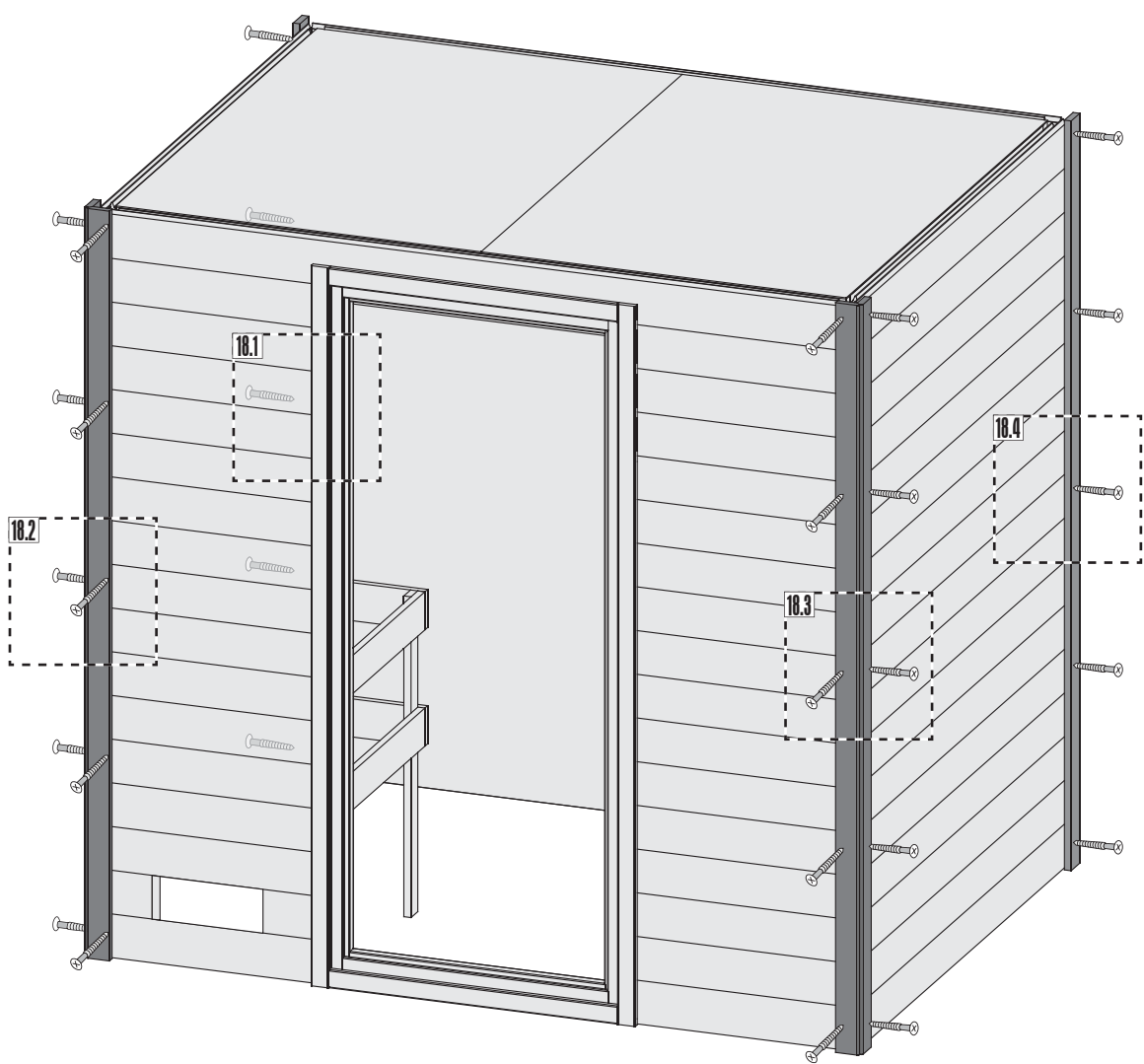

18.1

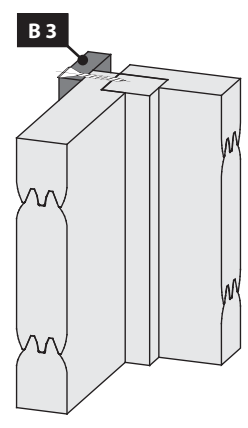

18.2

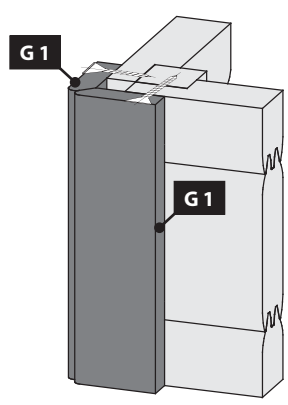

18.3

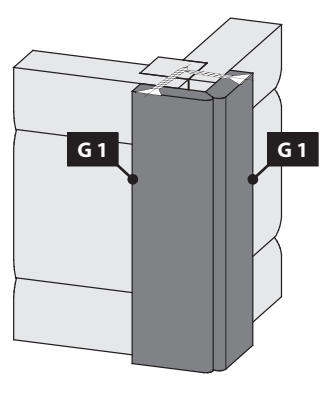

18.4

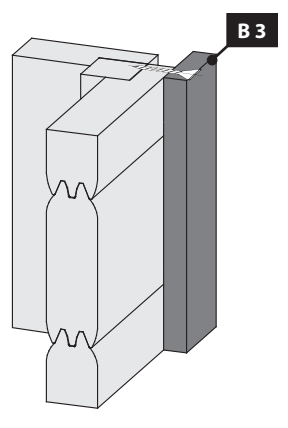

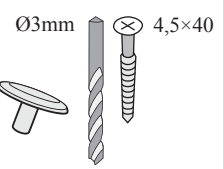

Bündig!  
Affleurement!  
Gelijk!  
Aras!  
Flush!  
Combacia!  
Stejný!

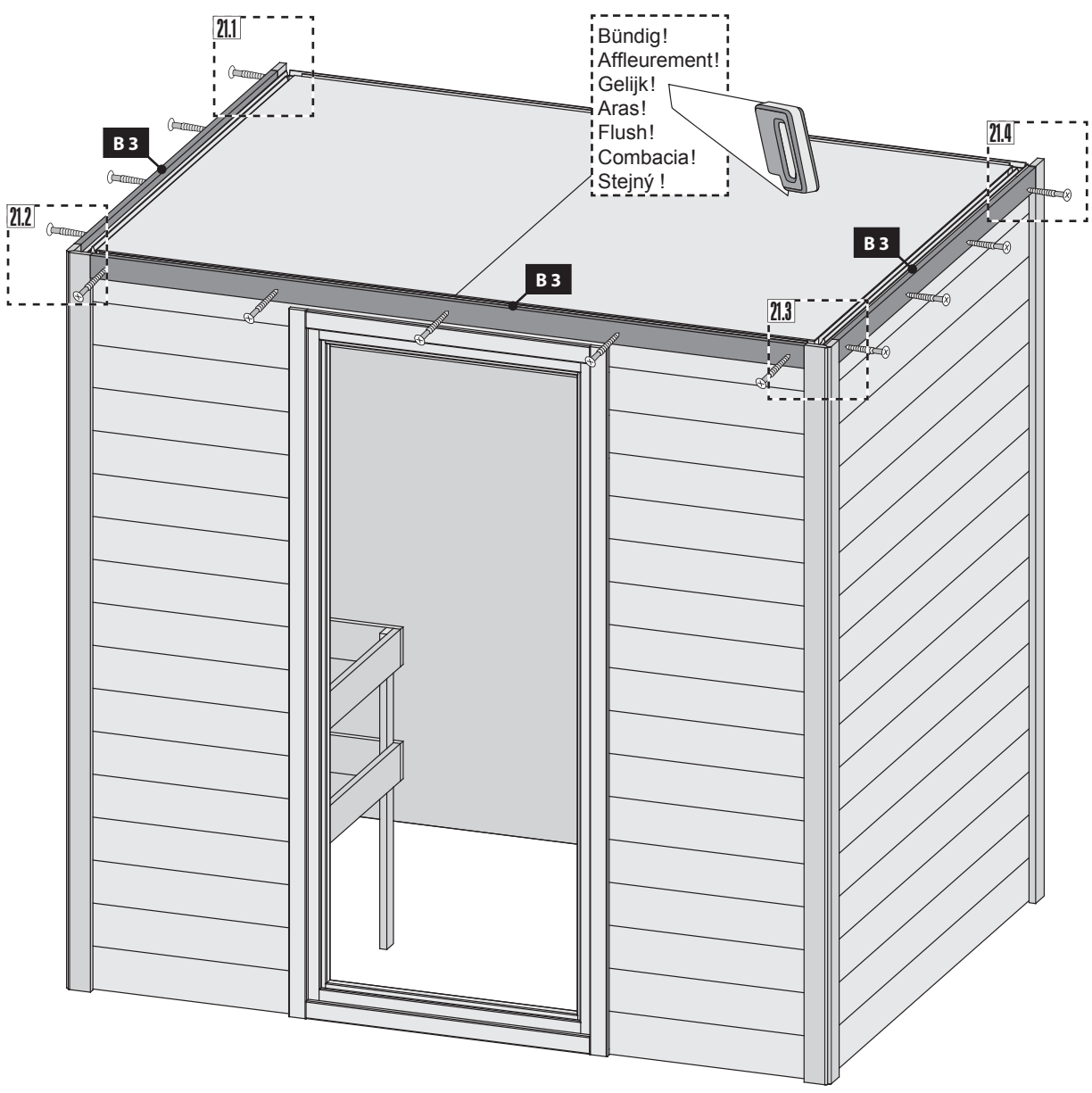

21.1

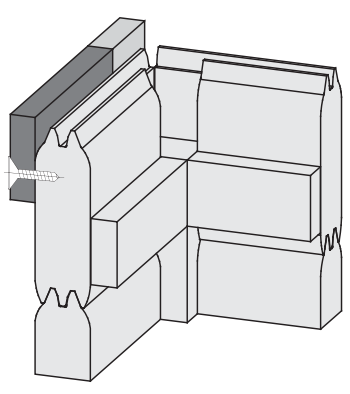

21.3

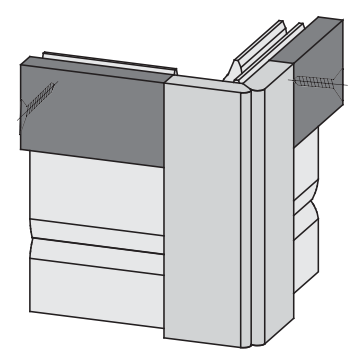

21.2

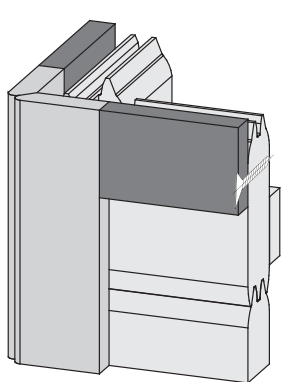

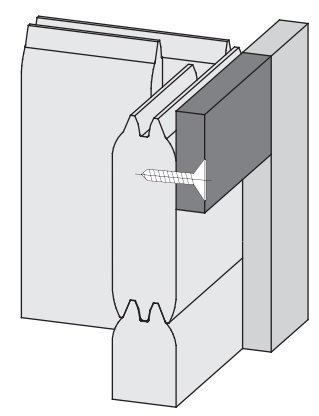

21.4

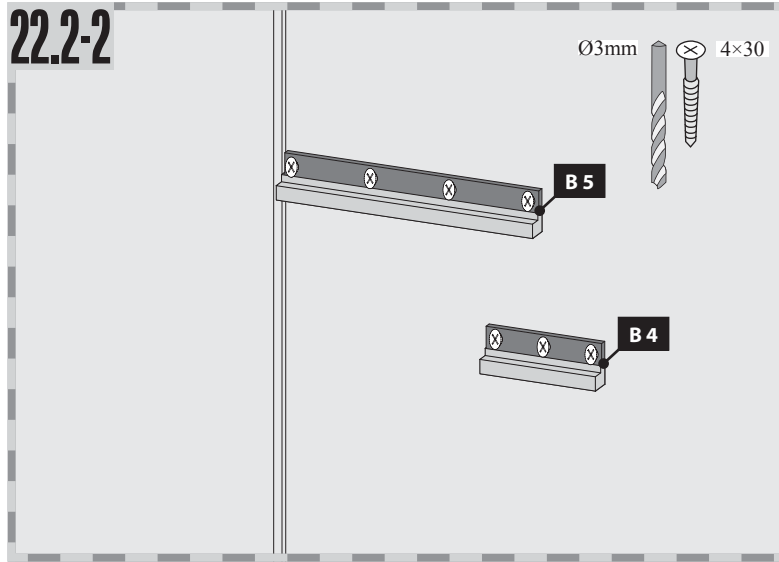
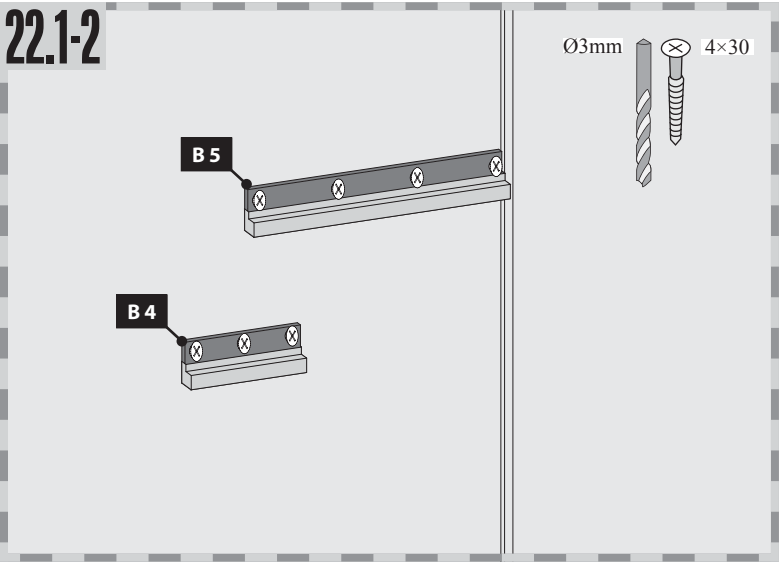
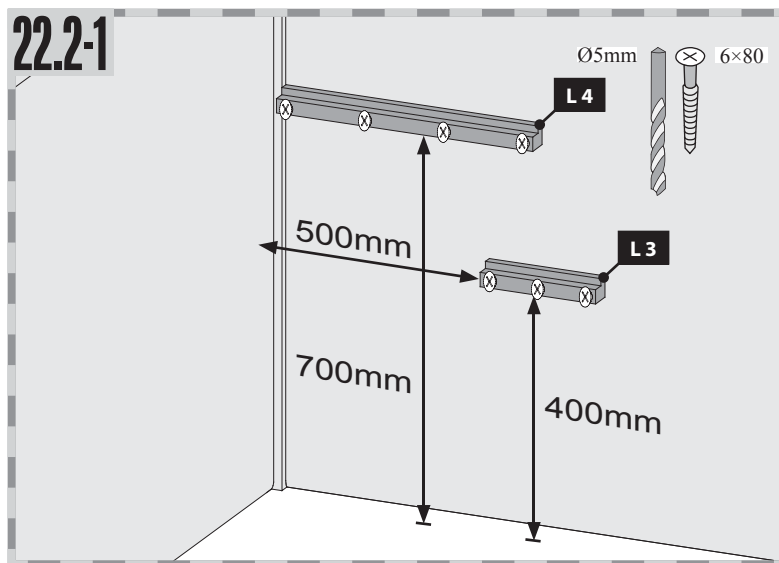
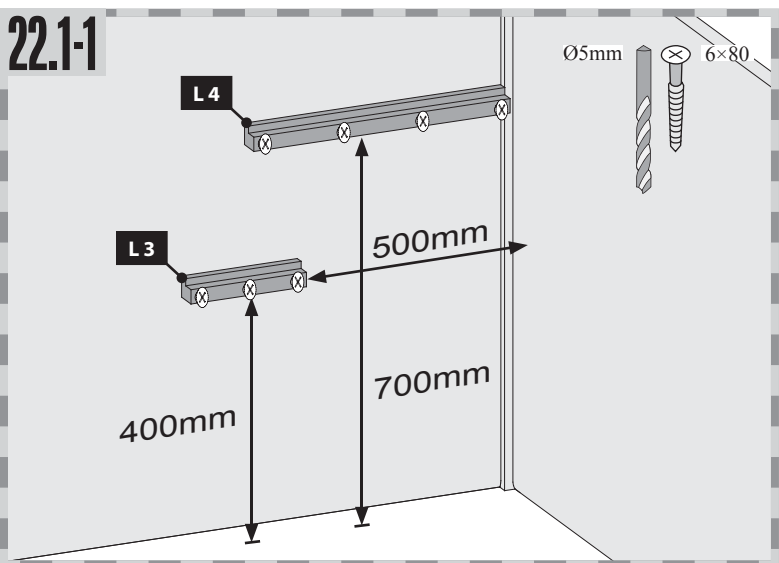
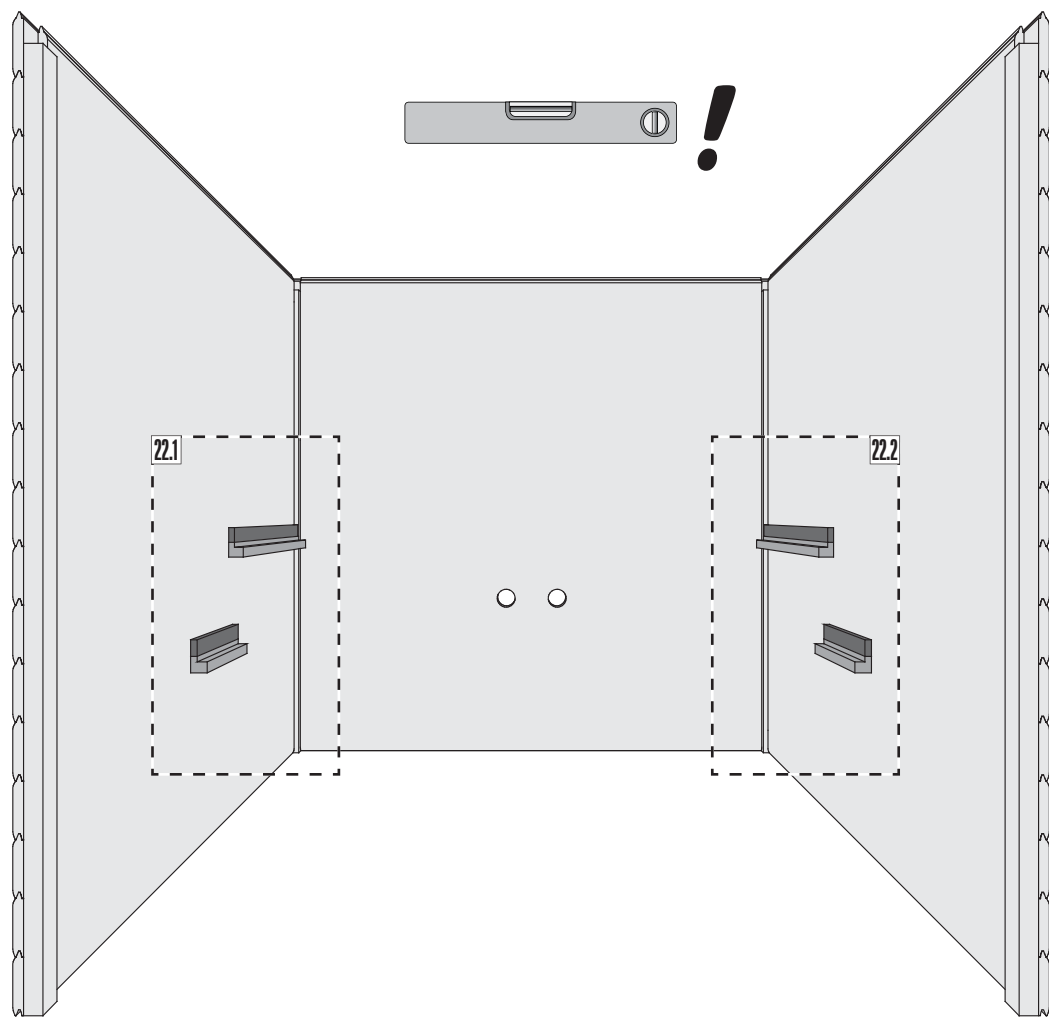

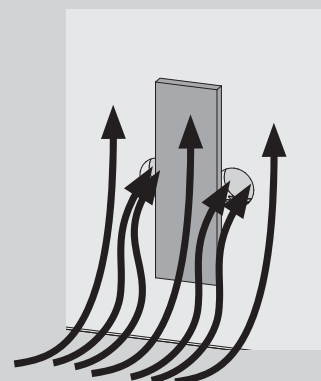
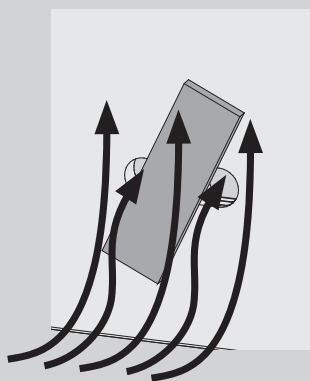
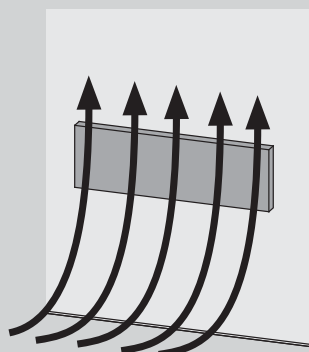
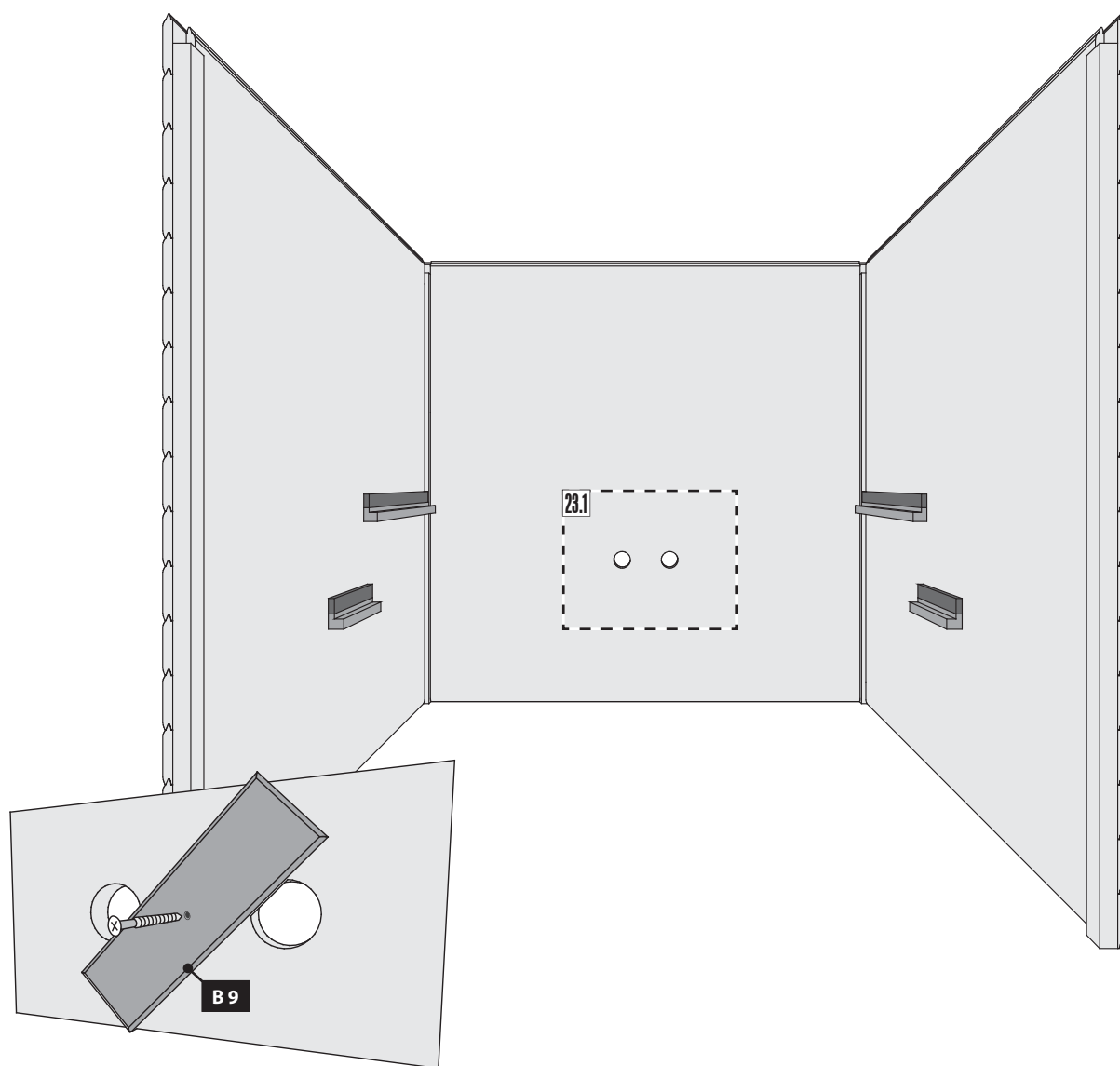
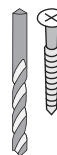







 Hier ist die Funktionsweise des Brettes abgebildet. Regeln Sie damit die Abluft nach Ihren eigenen Wünschen.

 Ceci représente le mode de fonctionnement de la planche. Avec elle, réglez l'écoulement de l'air selon vos désirs.

 This figure shows the functional principle of the board. Regulate the exhaust air according to your own wishes.

 Hier is de werking van het plankje afgebeeld. Regel daarmee de luchtafvoer naar eigen wens.

 Aquí está representada la forma de funcionamiento de la tabla. Regule con ello el aire de salida según sus propios deseos.

 Viene illustrato il principio di funzionamento della tavoletta di regolazione della ventilazione. Con essa si può regolare a piacere la ventilazione.

 Zde je zobrazená funkce desky. Regulujte s ní odsávací vzduch dle Vašeho přání.

24 2x

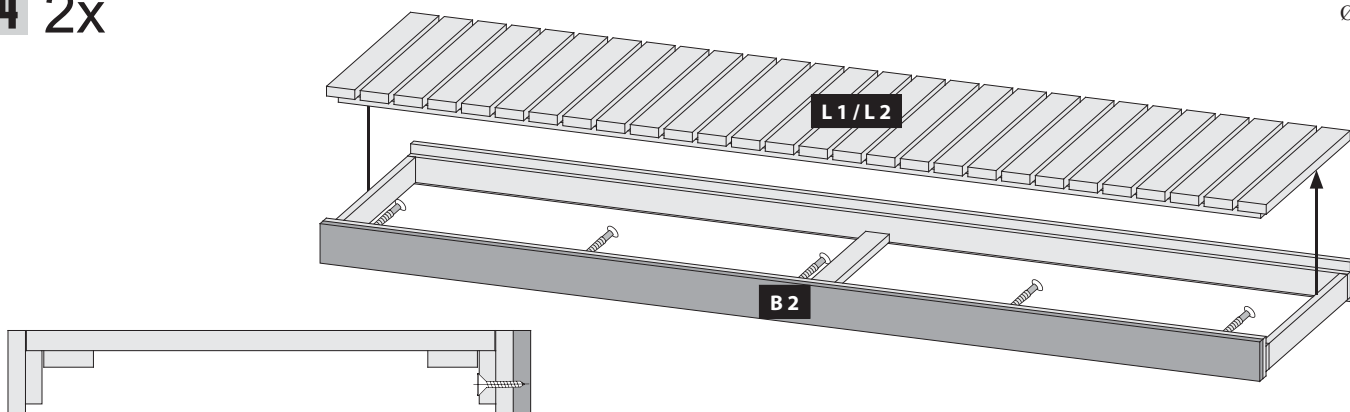

Ø3mm 4x40





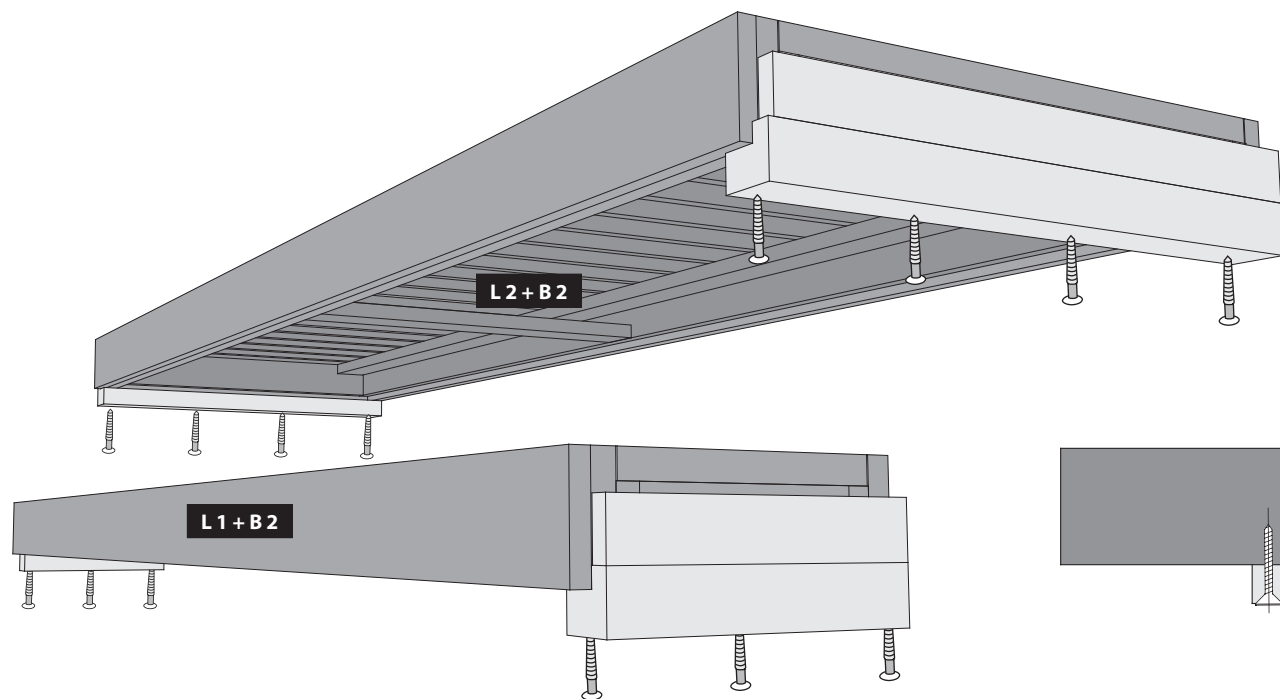
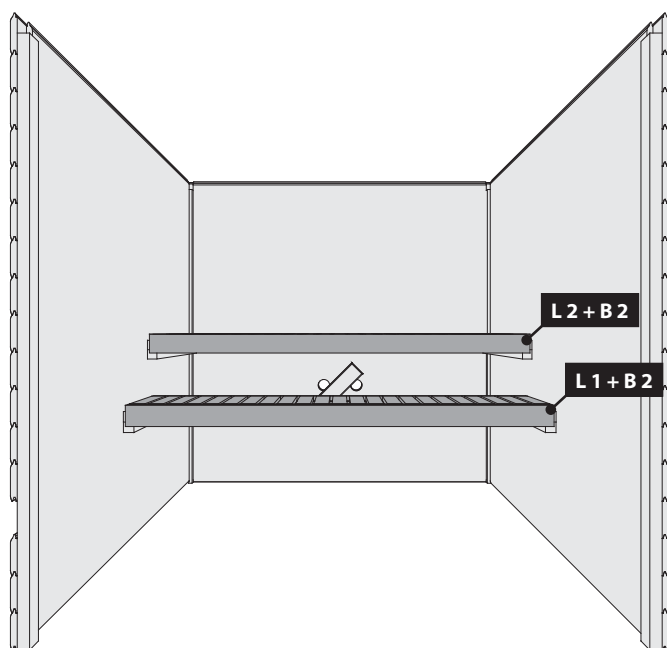

25

Ø3mm 4x40



-  Einbau Glastür
-  Montage porte en verre
-  Installation of glass door

-  Montage van de glazen deur
-  Montaje de la puerta de cristal

-  Installazione portello di vetro
-  Sauna Instalace dveře

!!! 04 — 08 !!!

# 66683

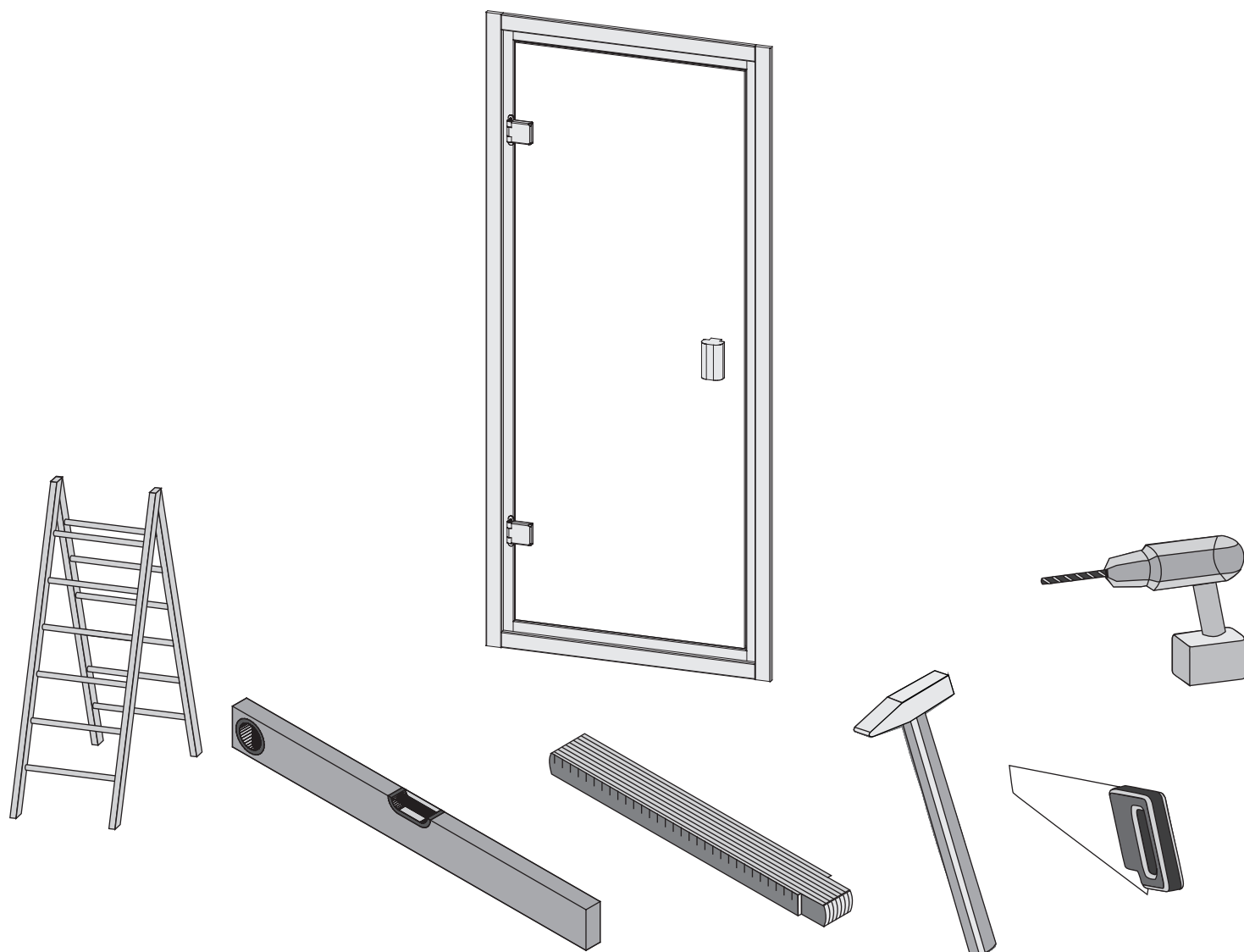

**Aufbauanleitung**



**notice de montage**



**Building Instructions**



**montagehandleiding**



**Instrucciones de construcción**



**Istruzioni per il montaggio**



**Montážní návod**



**Service-Hotline: +49 421 38693 33**





Vergleichen Sie zuerst die Materialliste mit Ihrem Paketinhalt! Bitte haben Sie Verständnis, dass Beanstandungen nur im nicht aufgebauten Zustand bearbeitet werden können!



En primer lugar, compare la lista de material con el contenido del paquete. Rogamos entienda que las reclamaciones sólo pueden ser tramitadas antes de montar el objeto!



Nejprve přezkontrolujte obsah balení podle materiálového listu! Mějte pochopení pro to, že případnou reklamaci se můžeme zabývat pouze tehdy, když díly nebudou smontované! Za pomoci tohoto seznamu můžete jednotlivé díly přiřadit k montážnímu návodu.



Vergelijk eerst de lijst van materialen met de inhoud van uw pakket! Reclamaties kunnen alleen in behandeling worden genomen zolang de onderdelen nog niet zijn gemonteerd!



First compare the list of materials with your package contents! Please understand that complaints can be processed in the non-built status only!



Commencez par comparer la liste du matériel avec le contenu de votre paquet! Sachez que nous traitons uniquement les réclamations concernant le matériel à l'état non monté!



Confrontate questa distinta materiali prima con il contenuto del pacchetto! Vi preghiamo di comprendere che eventuali reclami possono essere accolti solo prima del montaggio!

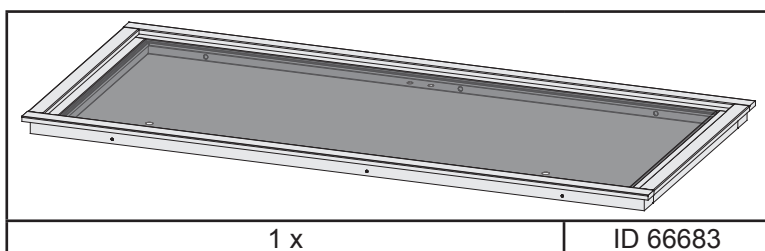
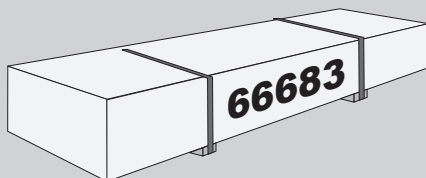

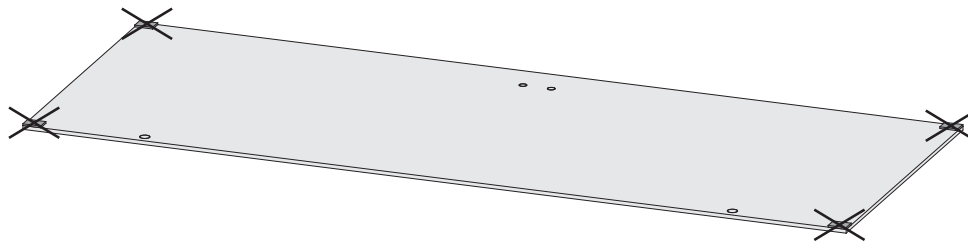
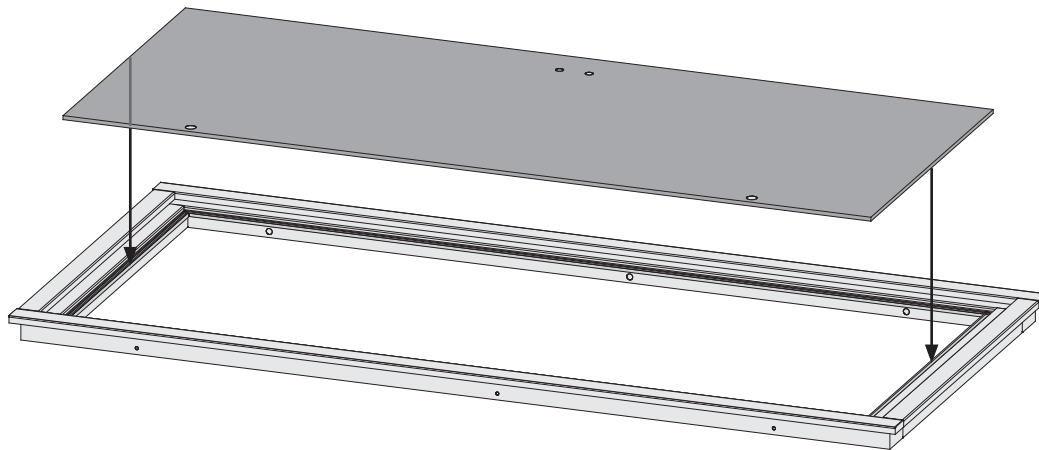
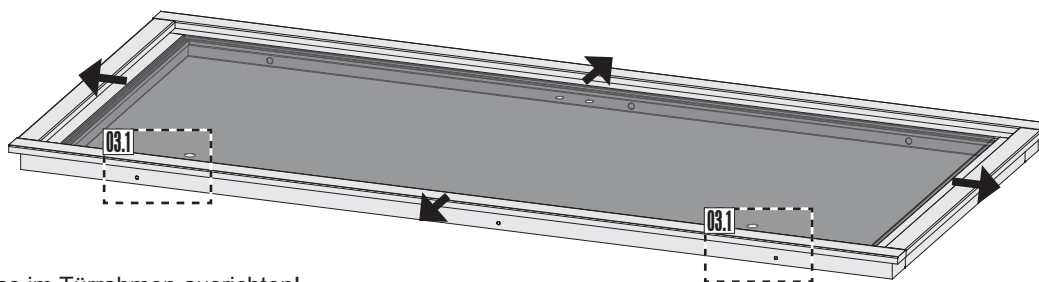
**01****02****03**

- Das Saunätürglas im Türrahmen ausrichten!
- Bien aligner le verre à vitre!
- To start building up the door you need to center the glass in the wooden frame!
- Plaats het glas van de sauna deur in het midden van het kozijn!
- ¡Centrar la puerta de cristal dentro del marco!
- Allineare il vetro dello sportello sauna al telaio della porta!
- Skleněná dvířka sauna v zárubně zarovnáni!

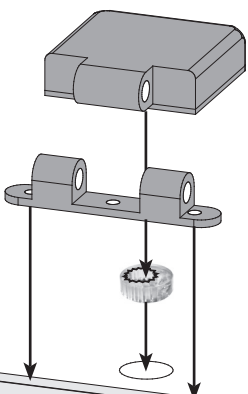
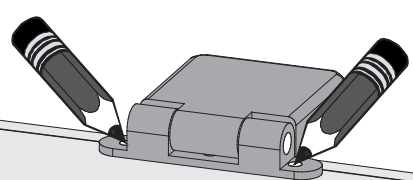
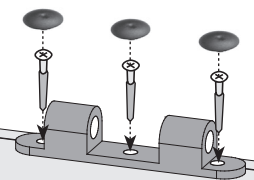
**03.1-1****03.1-2****03.1-3**

 Einbau Saunatür

 Sauna deur installatie

 Sauna Instalace dveře

 Installation de porte Sauna

 Instalación de la puerta Sauna

 Sauna door installation

 Installazione porta Sauna

04

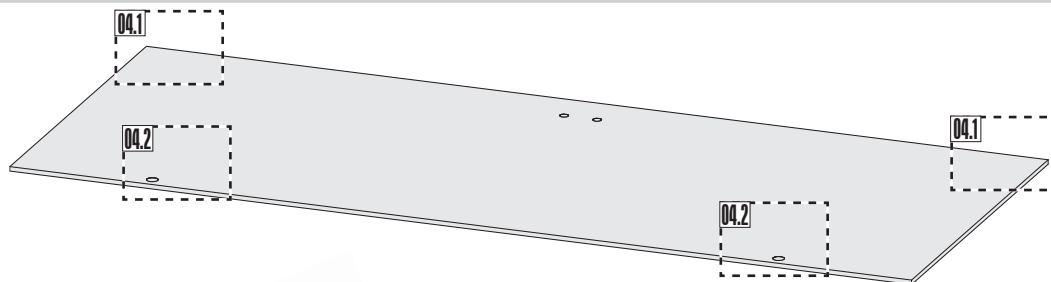

04.1-1

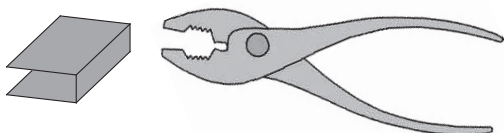

04.1-2

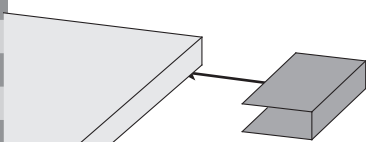

04.1-3

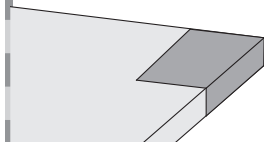

04.2-1

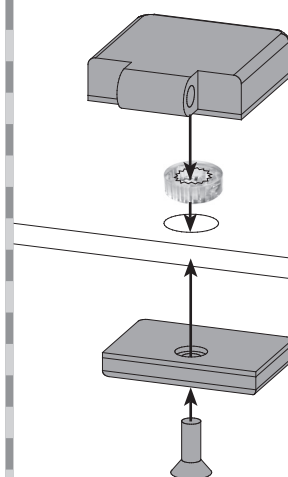

04.2-2

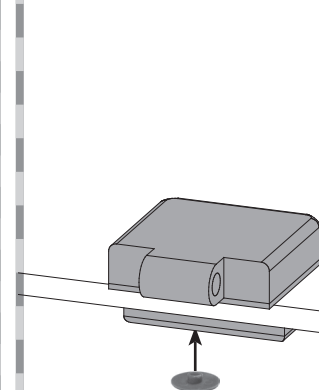

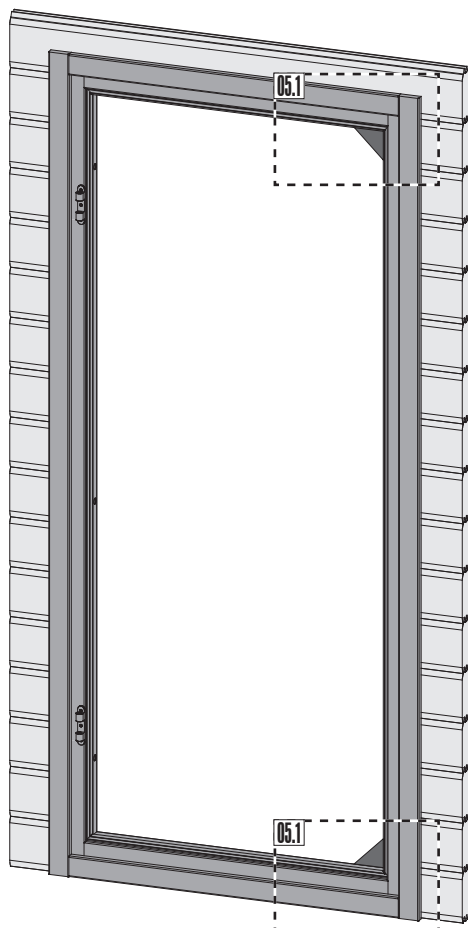

05





 Achtung: Alle Verstell-Excenter müssen in der Glasscheibe die gleiche Grundstellung haben!

 Attention: Tous les excenteurs de positionnement doivent avoir la même position de base dans la vitre!

 Attention: All adjustable eccentrics must have the same basic adjustment in the glass panel!

 Figyelmeztetés: az állítható excentrikusok ugyanabban a helyzetben kell, hogy legyenek a üveglapon!

 Atención: Todos los excéntricos regulables tienen que tener la misma posición base en la hoja de cristal.

 Attenzione: Tutti gli eccentrici di regolazione devono avere la stessa posizione base nella lastra di vetro!

 Poznámka: Všechny nastavovací podivínů musí mít stejný základní polohy ve skle!

05.1-1

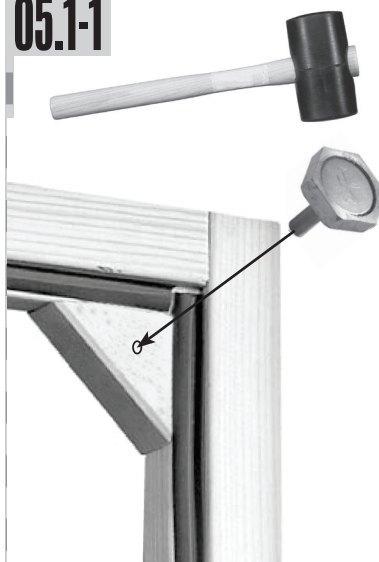

05.1-2



 Einbau Saunatür

 Sauna deur installatie

 Sauna Instalace dveře

 Installation de porte Sauna

 Instalación de la puerta Sauna

 Sauna door installation

 Installazione porta Sauna

06

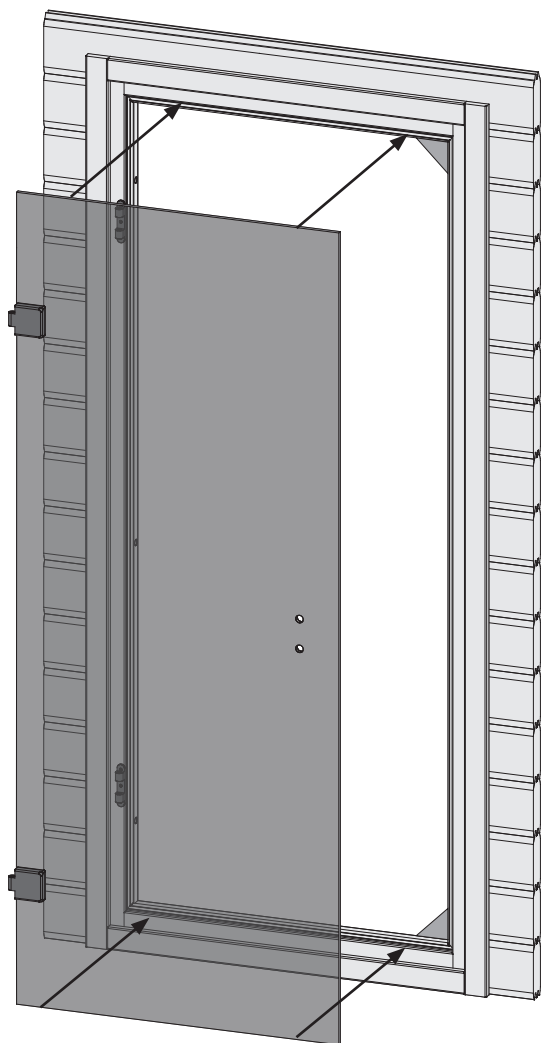

07

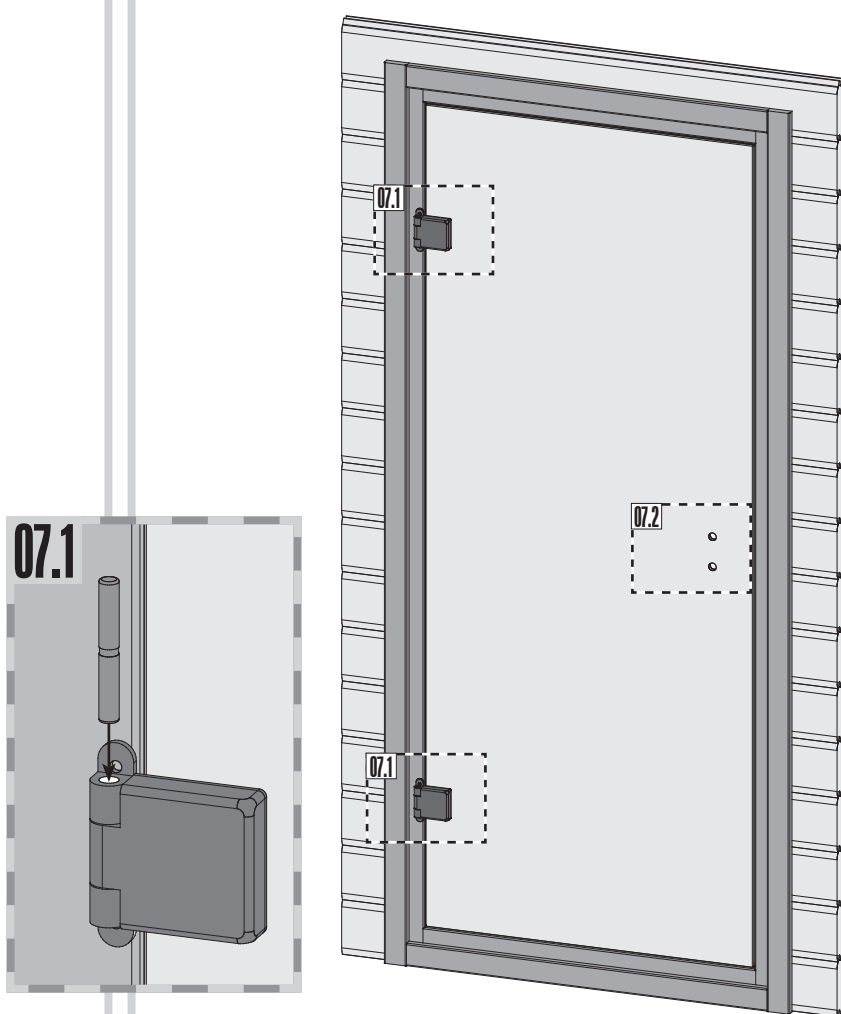

07.2-1

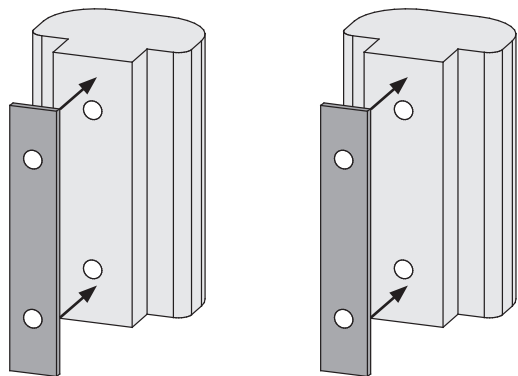

07.2-2

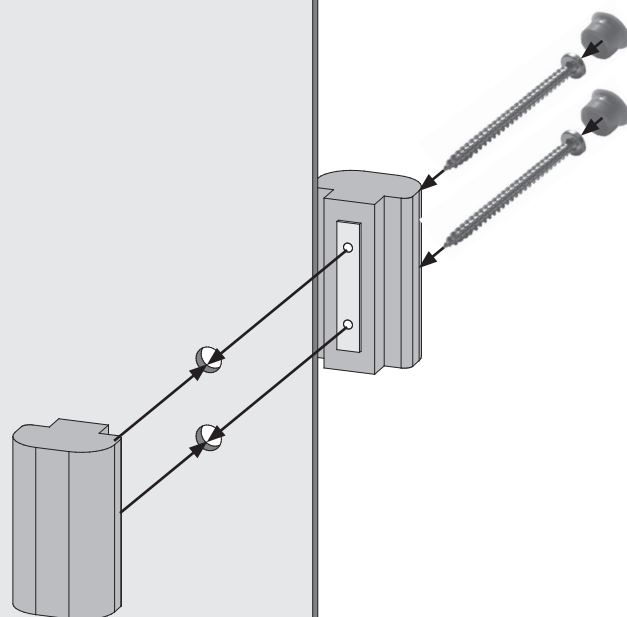

 Einbau Saunatür

 Sauna deur installatie

 Sauna Instalace dveře

 Installation de porte Sauna

 Instalación de la puerta Sauna

 Sauna door installation

 Installazione porta Sauna

08

### **Seitenverstellung + Höhenverstellung**

Achtung: Alle Verstell-Excenter müssen in der Glasscheibe die gleiche Grundstellung haben!

### **Positionnement latéral + positionnement hauteur**

Attention: Tous les excentrés de positionnement doivent avoir la même position de base dans la vitre!

### **Lateral adjustment + height adjustment**

Attention: All adjustable eccentrics must have the same basic adjustment in the glass panel!

### **Zijverstelling + hoogteverstelling**

Attentie: alle excentrische verstelelementen moeten in dezelfde stand in de glasplaat worden geplaatst!

### **Regulación lateral + regulación de la altura**

Atención: Todos los excéntricos regulables tienen que tener la misma posición base en la hoja de cristal.

### **Regolazione laterale + regolazione dell'altezza**

Attenzione: Tutti gli eccentrici di regolazione devono avere la stessa posizione base nella lastra di vetro!

### **Boční nastavení + nastavení výšky**

Poznámka: Všechny nastavovací podivínů musí mít stejný základní polohy ve skle!

